

Design and Detailing of Retaining Wall

Prepared By

Shoxan Abdulrahman Mohammed

DESIGN AND DETAILING OF RETAINING WALLS

Learning Outcomes:

- After this class students will be able to do the complete design and detailing of different types of retaining walls.

RETAINING WALL

Retaining walls are usually built to hold back soil mass. However, retaining walls can also be constructed for aesthetic landscaping purposes.

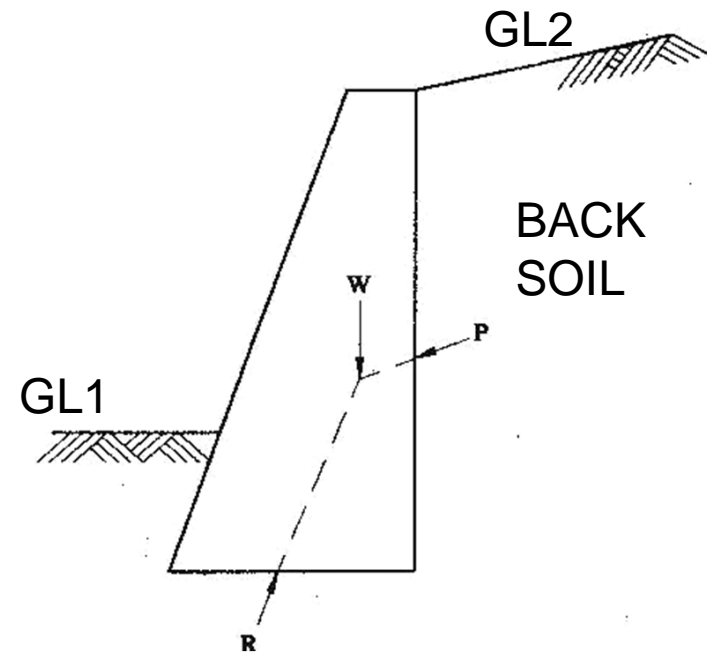

Gravity retaining wall

Cantilever Retaining wall with shear key

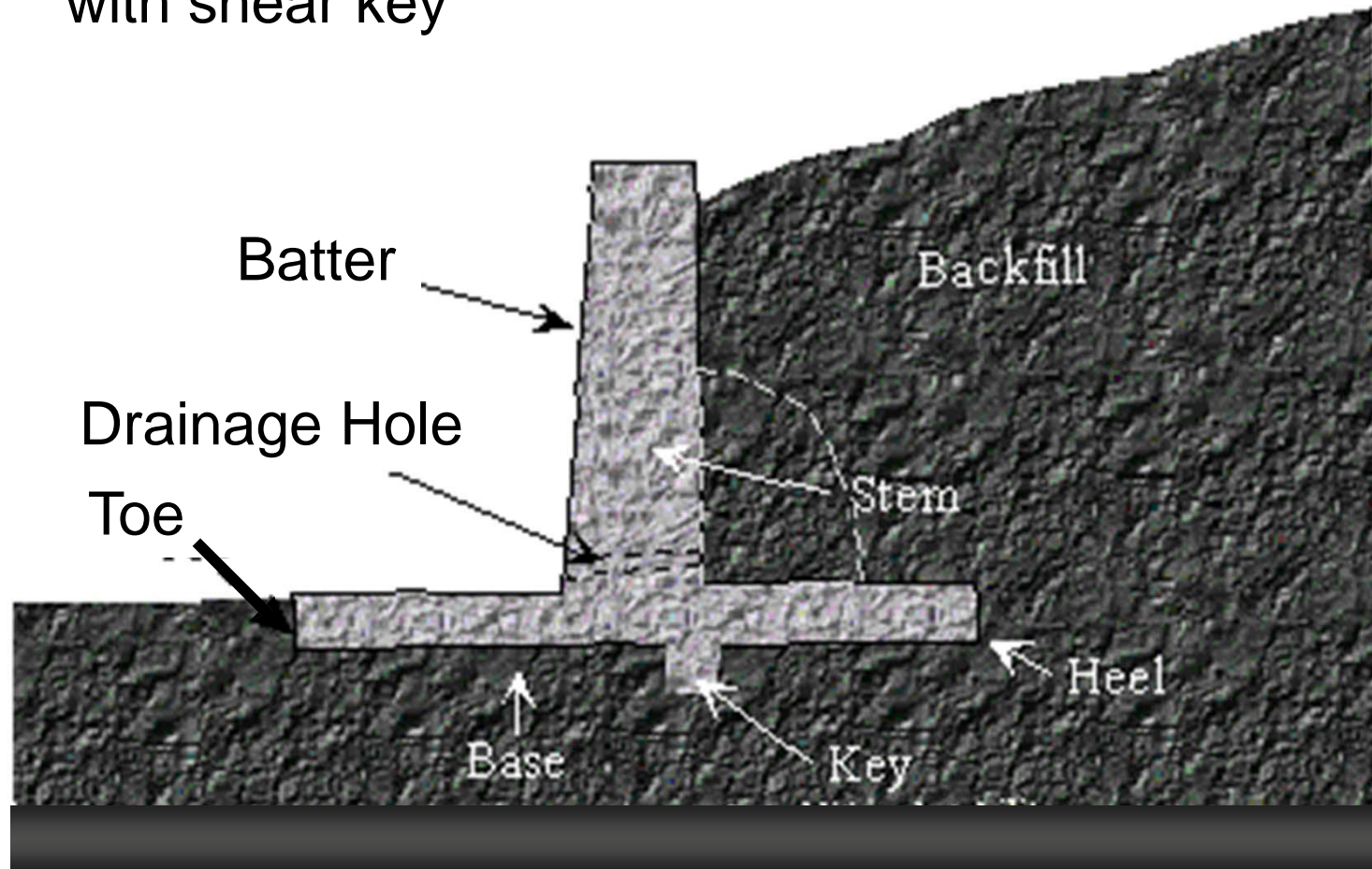

Photos of Retaining walls



Classification of Retaining walls

- Gravity wall-Masonry or Plain concrete
- Cantilever retaining wall-RCC
(Inverted T and L)
- Counterfort retaining wall-RCC
- Buttress wall-RCC

Classification of Retaining walls

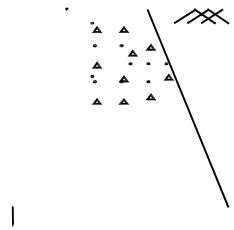

Gravity RW

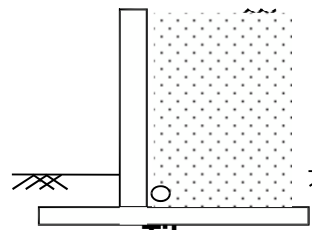

Tile drain
T-Shaped RW

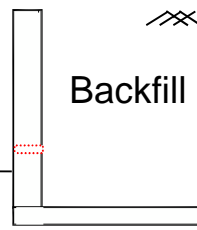

Backfill

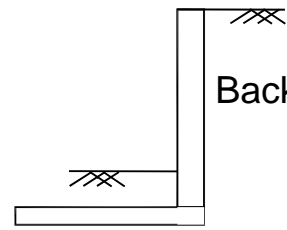

Backfill

L-Shaped RW

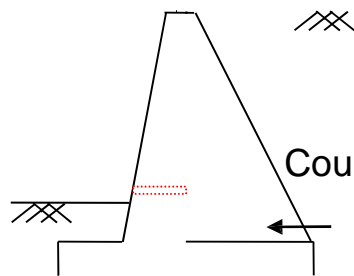

Counterfort

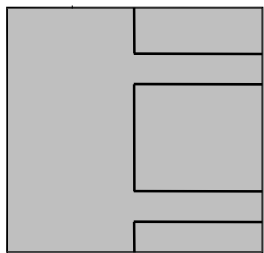

Counterfort RW

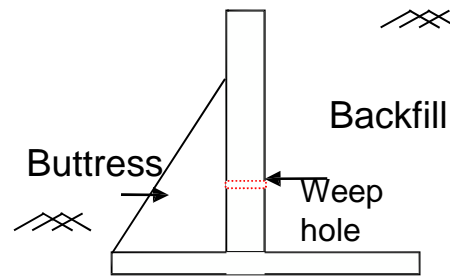

Buttress

Backfill

Weep hole

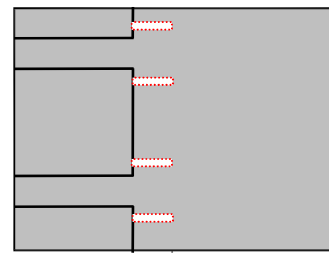

Buttress RW

Earth Pressure (P)

- Earth pressure is the pressure exerted by the pressure tends to deflect the wall outward.
- **Types of earth pressure :**
- Active earth pressure or earth pressure (P_a) and
- Passive earth pressure (P_p).
- Active earth pressure tends to deflect the wall away from the backfill.

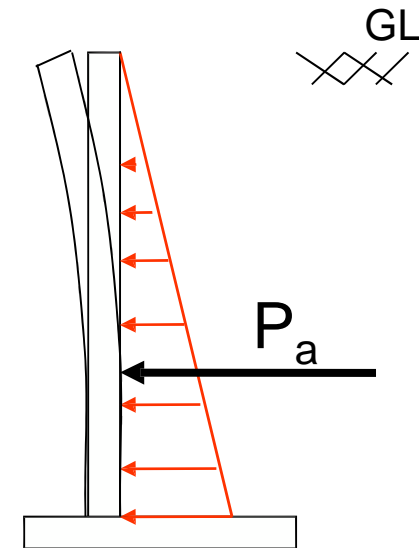

Variation of Earth pressure

Factors affecting earth pressure

- Earth pressure depends on type of backfill, the height of wall and the soil conditions

Soil conditions: The different soil conditions are

- Dry leveled back fill
- Moist leveled backfill
- Submerged leveled backfill
- Leveled backfill with uniform surcharge
- Backfill with sloping surface

Analysis for dry back fills

Maximum pressure at any height, $p = k_a \gamma h$

Total pressure at any height from top,
 $p_a = 1/2 [k_a \gamma h] h = [k_a \gamma h^2]/2$

Bending moment at any height

$$M = p_a x h / 3 = [k_a \gamma h^3] / 6$$

\therefore Total pressure, $P_a = [k_a \gamma H^2] / 2$

\therefore Total Bending moment at bottom,

$$M = [k_a \gamma H^3] / 6$$

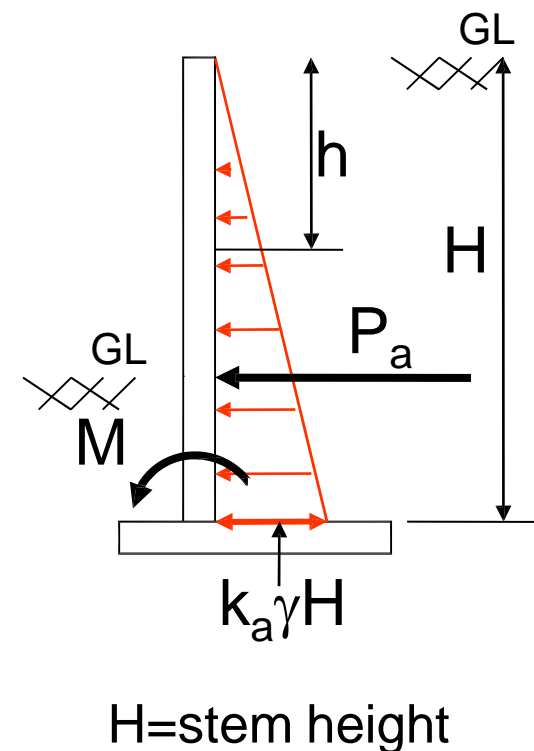

- Where, k_a = Coefficient of active earth pressure
- $= (1 - \sin\phi) / (1 + \sin\phi) = \tan^2\phi$
- $= 1 / k_p$, coefficient of passive earth pressure
- ϕ = Angle of internal friction or angle of repose
- γ = Unit weight or density of backfill
- If $\phi = 30^\circ$, $k_a = 1/3$ and $k_p = 3$. Thus k_a is 9 times k_p

Backfill with sloping surface

- $p_a = k_a \gamma H$ at the bottom and is parallel to inclined surface of backfill

- $k_a = \cos\theta \left[\frac{\cos\theta - \sqrt{\cos^2\theta - \cos^2\phi}}{\cos\theta + \sqrt{\cos^2\theta - \cos^2\phi}} \right]$

- Where $\theta =$ Angle of surcharge

\therefore Total pressure at bottom

$$= P_a = k_a \gamma H^2 / 2$$

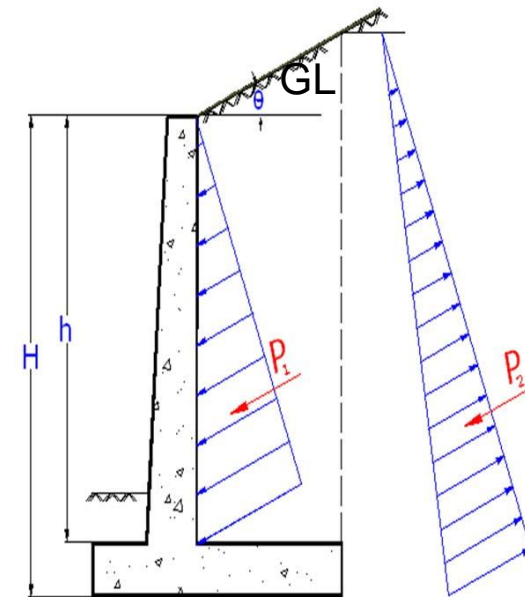

SOIL PRESSURE DUE TO INCLINED SURCHARGE

Stability requirements of RW

- Following conditions must be satisfied for stability of wall (IS:456-2000).
- **It should not overturn**
- **It should not slide**
- **It should not subside**, i.e Max. pressure at the toe should not exceed the safe bearing capacity of the soil under working condition

Check against overturning

Factor of safety against overturning

$$= M_R / M_O \geq 1.55 (=1.4/0.9)$$

Where,

M_R = Stabilising moment or restoring moment

M_O = overturning moment

As per IS:456-2000,

$$M_R > 1.2 M_O, \text{ ch. DL} + 1.4 M_O, \text{ ch. IL}$$

$$0.9 M_R \geq 1.4 M_O, \text{ ch IL}$$

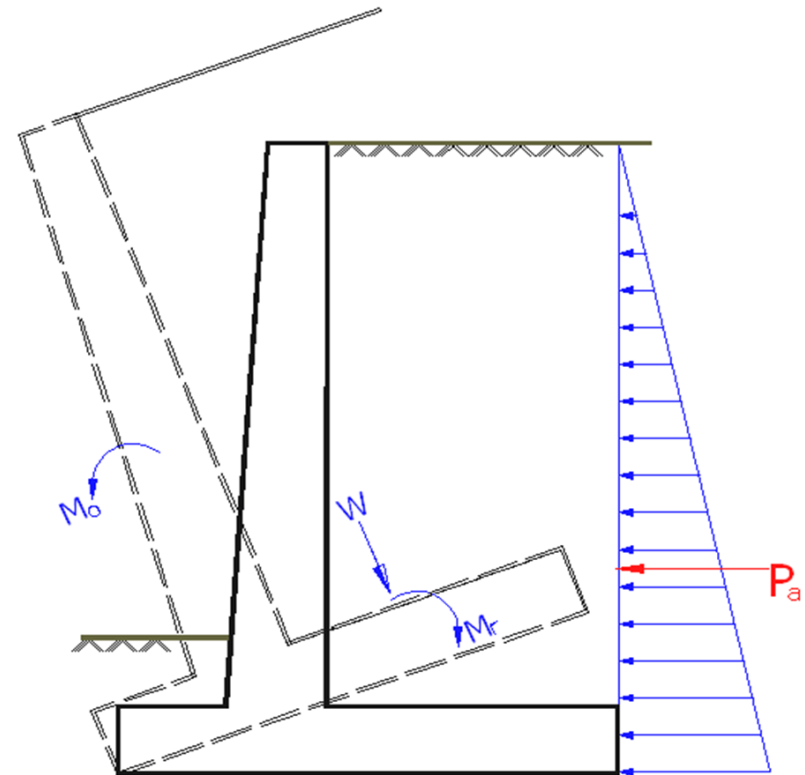

OVERTURNING OF WALL

Check against Sliding

- FOS against sliding
- = Resisting force to sliding /
- Horizontal force causing
- sliding
- = $\mu \sum W / P_a \geq 1.55$
(=1.4/0.9)
- As per IS:456:2000
- $1.4 = \mu(0.9 \sum W) / P_a$

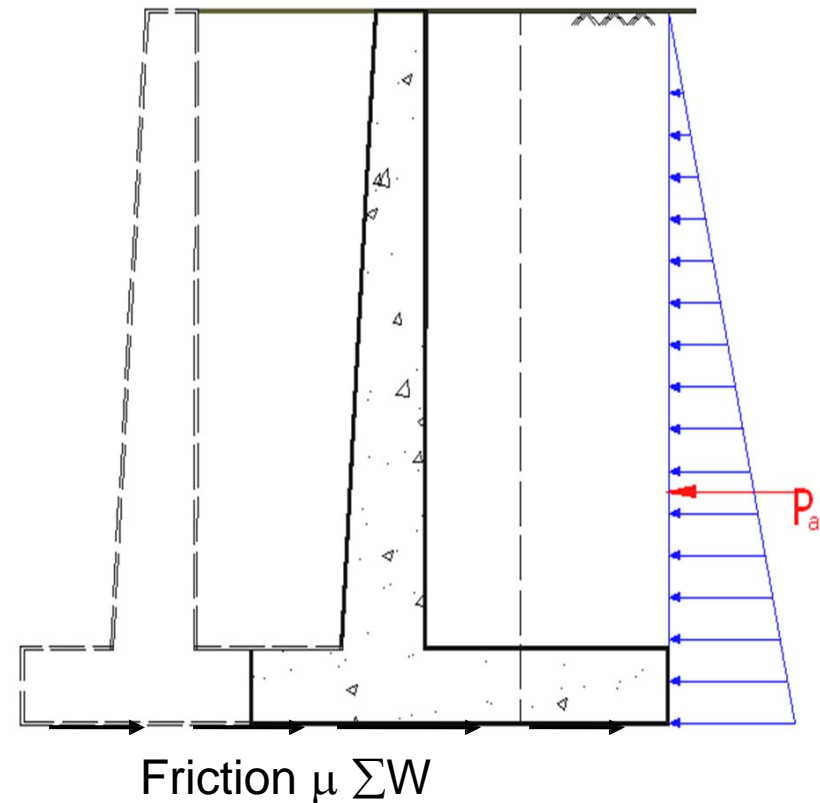

SLIDING OF WALL

Design of Shear key-Contd.,

- If $\sum W =$ Total vertical force acting at the key base
- $\phi =$ shearing angle of passive resistance
- $R =$ Total passive force $= p_p \times a$
- $P_A =$ Active horizontal pressure at key base for $H+a$
- $\mu \sum W =$ Total frictional force under flat base

- For equilibrium, $R + \mu \sum W = \text{FOS} \times P_A$

- $\text{FOS} = (R + \mu \sum W) / P_A \geq 1.55$



Maximum pressure at the toe

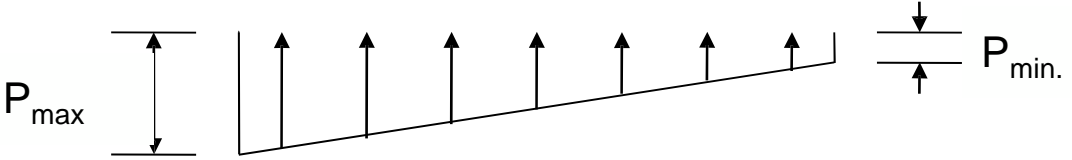
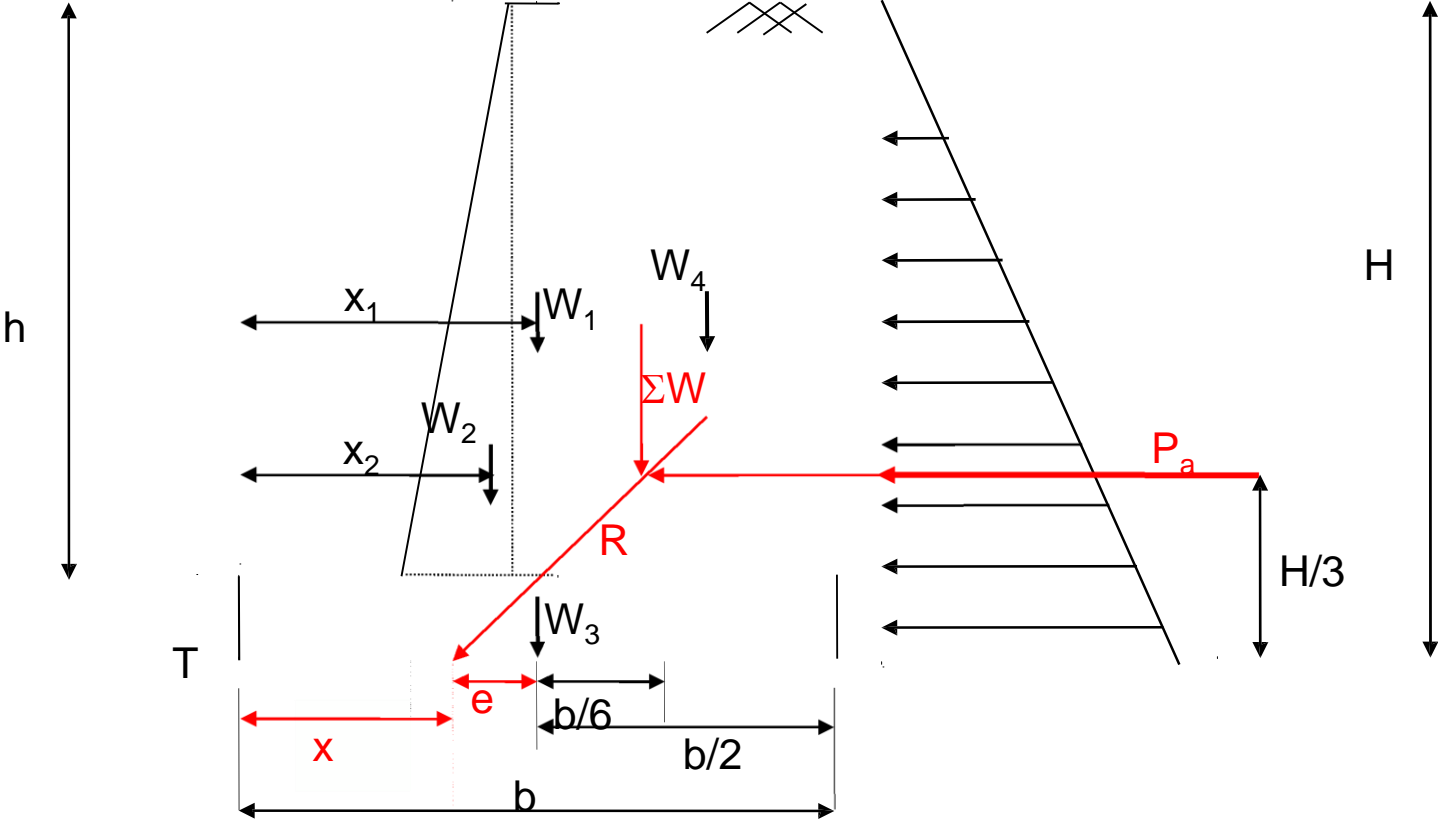

Pressure below the Retaining Wall

- Let the resultant R due to $\sum W$ and P_a
- lie at a distance x from the toe.
- $X = \sum M / \sum W$,
- $\sum M =$ sum of all moments about toe.

- Eccentricity of the load = $e = (b/2 - x) < b/6$
- Minimum pressure at heel = $P_{\min} = \frac{\sum W}{b} \left[1 - \frac{6e}{b} \right] > \text{Zero.}$
- For zero pressure, $e = b/6$, resultant should cut the base within the middle third.
- Maximum pressure at toe = $P_{\max} = \frac{\sum W}{b} \left[1 + \frac{6e}{b} \right]$
- $<$ SBC of soil.

Depth of foundation

- Rankine's formula:

- $$D_f = \frac{SBC}{\gamma} \left[\frac{1 - \sin \phi}{1 + \sin \phi} \right]^2$$
- $$= \frac{SBC}{\gamma} k_a^2$$

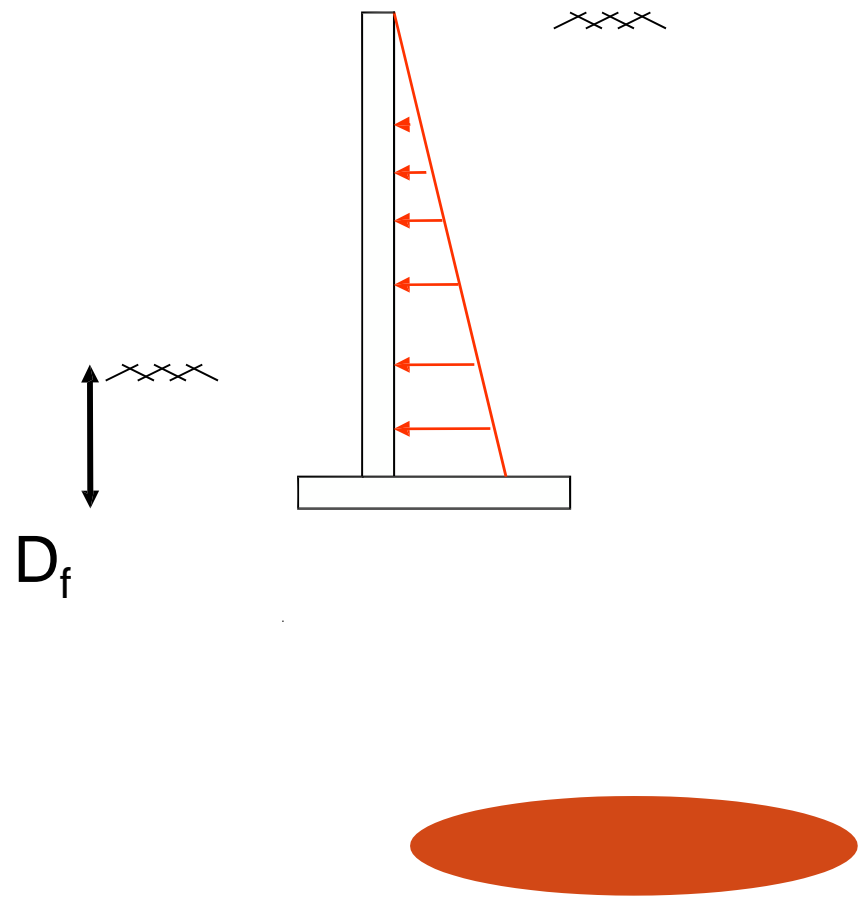

Preliminary Proportioning (T shaped wall)

- Stem: Top width 200 mm to 400 mm
- Base slab width $b = 0.4H$ to $0.6H$, $0.6H$ to $0.75H$ for surcharged wall
- Base slab thickness = $H/10$ to $H/14$
- Toe projection = $(1/3 - 1/4)$ Base width

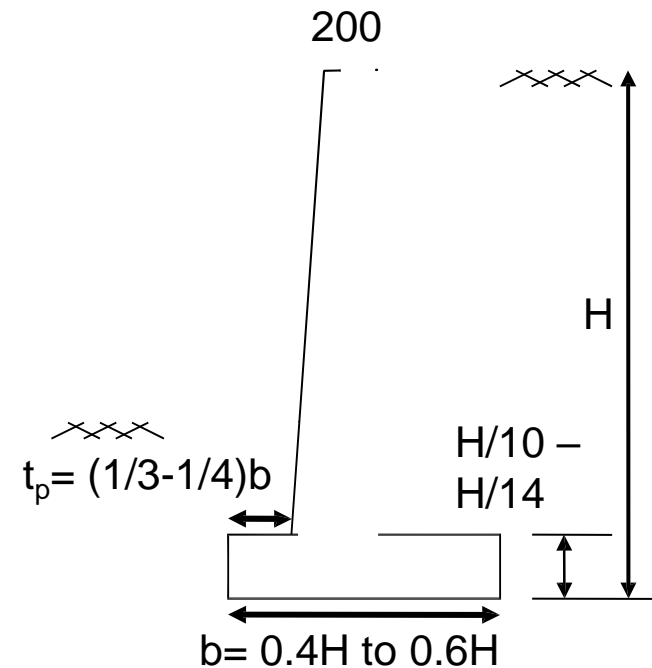

Behaviour or structural action

- Behaviour or structural action and design of stem, heel and toe slabs are same as that of any cantilever slab.

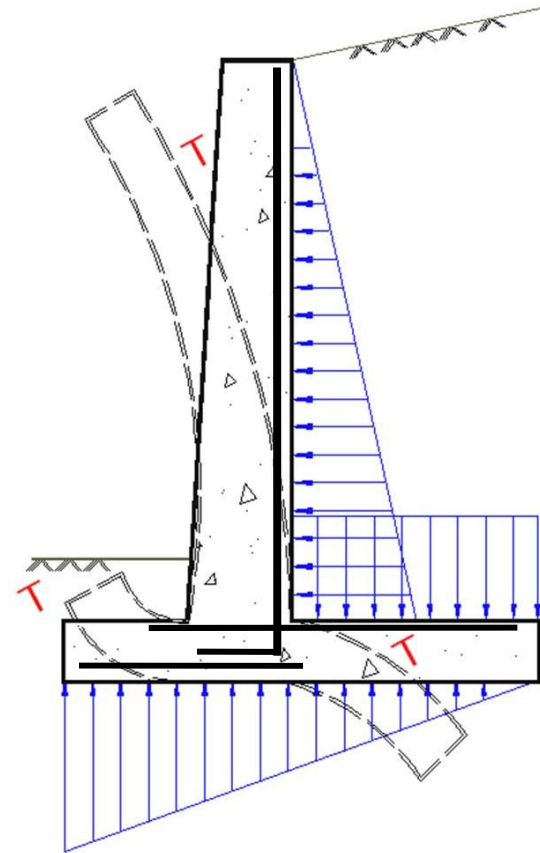

DEFORMATION UNDER LOADING

Design of Cantilever RW

- Stem, toe and heel acts as cantilever slabs
- Stem design: $M_u = p_s f (k_a \gamma H^3 / 6)$
- Determine the depth d from $M_u = M_{u, \text{lim}} = Qbd^2$
- Design as balanced section or **URS** and find steel
- $M_u = 0.87 f_y A_{st} [d - f_y A_{st} / (f_{ck} b)]$

Curtailment of bars

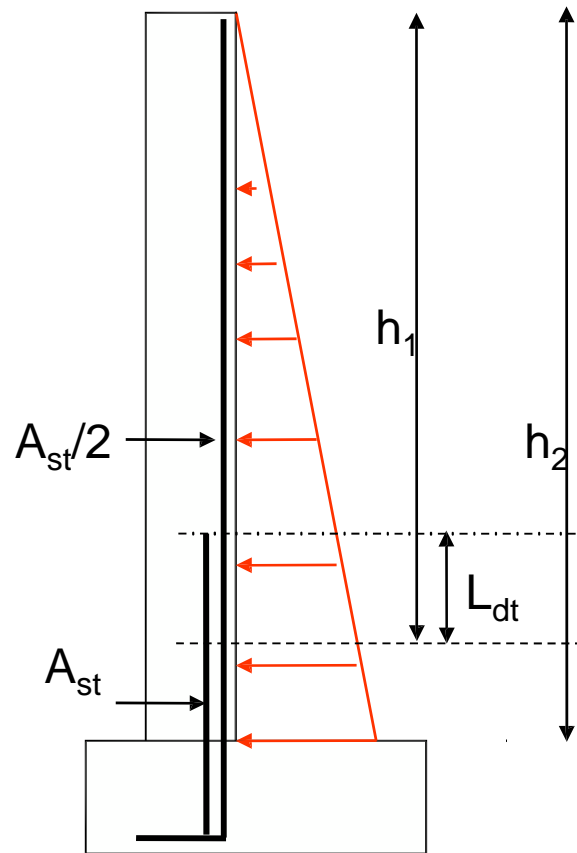

Cross section

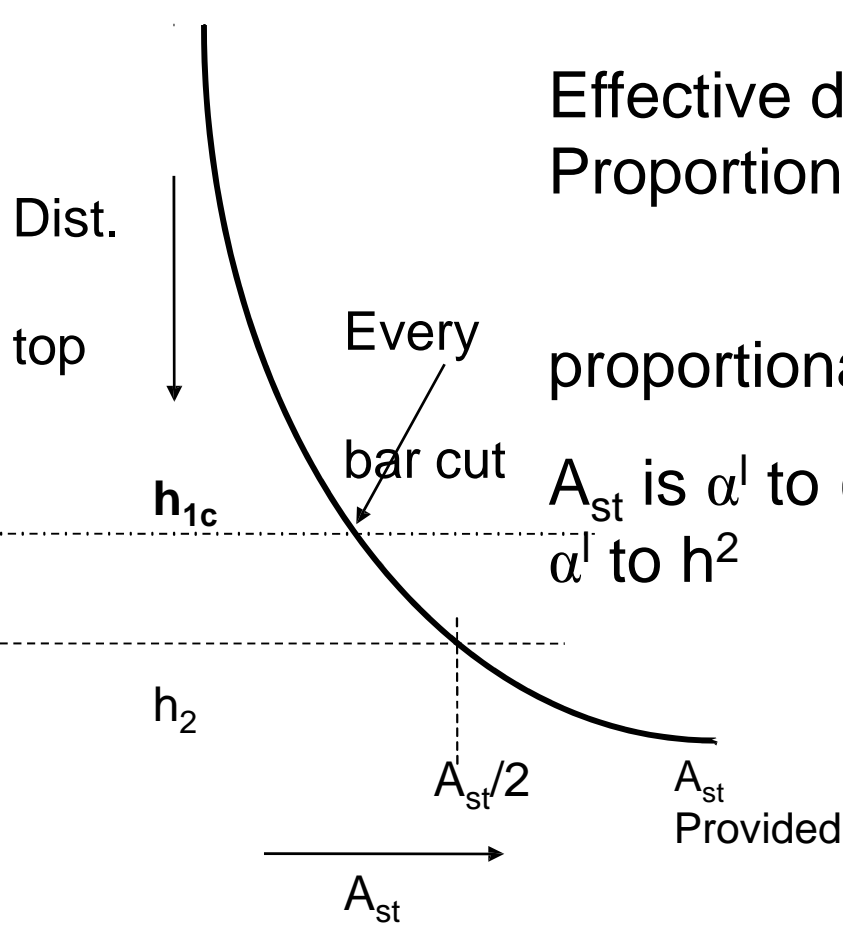

Curtailment curve

Effective depth (d) is Proportional to h

proportional to h^3

A_{st} is α^1 to (BM/ d) and is α^1 to h^2

$$i.e. \frac{A_{st1}}{A_{st2}} \approx \frac{h_1^2}{h_2^2}$$

Design of Heel and Toe

1. Heel slab and toe slab should also be designed as cantilever. For this stability analysis should be performed as explained and determine the maximum bending moments at the junction.
2. Determine the reinforcement.
3. Also check for shear at the junction.
4. Provide enough development length.
5. Provide the distribution steel

Design Example Cantilever retaining wall

Design a cantilever retaining wall (T type) to retain earth for a height of 4m. The backfill is horizontal. The density of soil is 18kN/m^3 . Safe bearing capacity of soil is 200 kN/m^2 . Take the co-efficient of friction between concrete and soil as 0.6. The angle of repose is 30° . Use M20 concrete and Fe415 steel.

Solution

Data: $h' = 4\text{m}$, $\text{SBC} = 200\text{ kN/m}^2$, $\gamma = 18\text{ kN/m}^3$, $\mu = 0.6$, $\phi = 30^\circ$

Depth of foundation

- To fix the height of retaining wall [H]

- $H = h' + D_f$

- Depth of foundation

- $$D_f = \frac{SBC}{\gamma} \left[\frac{1 - \sin \phi}{1 + \sin \phi} \right]^2$$

- = 1.23m say 1.2m ,

- Therefore $H = 5.2\text{m}$

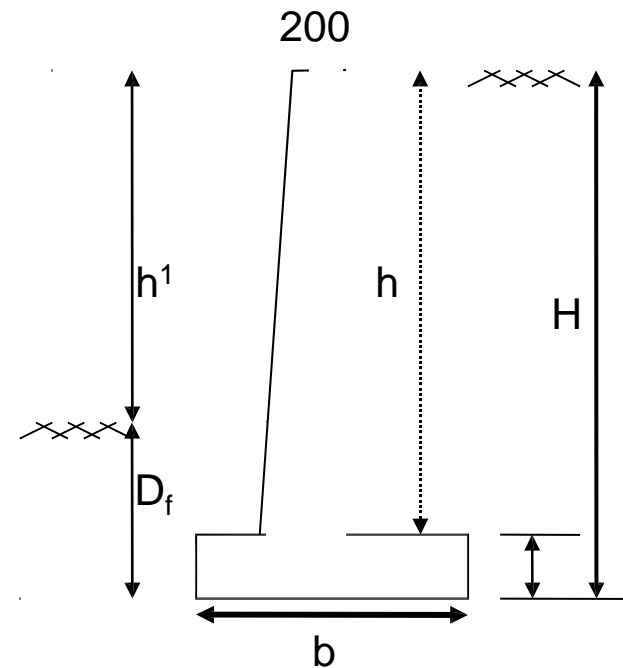

Proportioning of wall

- Thickness of base slab = $(1/10 \text{ to } 1/14)H$
- 0.52m to 0.43m, say 450 mm
- Width of base slab = $b = (0.5 \text{ to } 0.6) H$
- 2.6m to 3.12m say 3m
- Toe projection = $p_j = (1/3 \text{ to } 1/4)H$
- 1m to 0.75m say 0.75m
- Provide 450 mm thickness for the stem at the base and 200 mm at the top

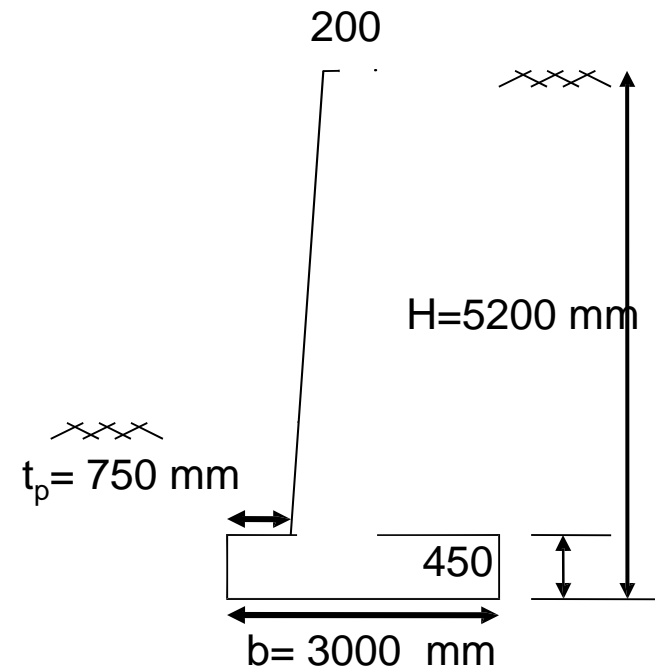

Design of stem

- $P_h = \frac{1}{2} \times \frac{1}{3} \times 18 \times 4.75^2 = 67.68 \text{ kN}$
- $M = P_h h/3 = 0.333 \times 18 \times 4.75^3/6$
- $= 107.1 \text{ kN-m}$
- $M_u = 1.5 \times M = 160.6 \text{ kN-m}$
- Taking 1m length of wall,
- $M_u/bd^2 = 1.004 < 2.76$, URS
- (Here $d=450$ - eff. Cover= $450-50=400$ mm)
- To find steel
- $P_t = 0.295\% < 0.96\%$
- $A_{st} = 0.295 \times 1000 \times 400 / 100 = 1180 \text{ mm}^2$
- #12 @ 90 < 300 mm and 3d ok
- $A_{st} \text{ provided} = 1266 \text{ mm}^2 [0.32\%]$

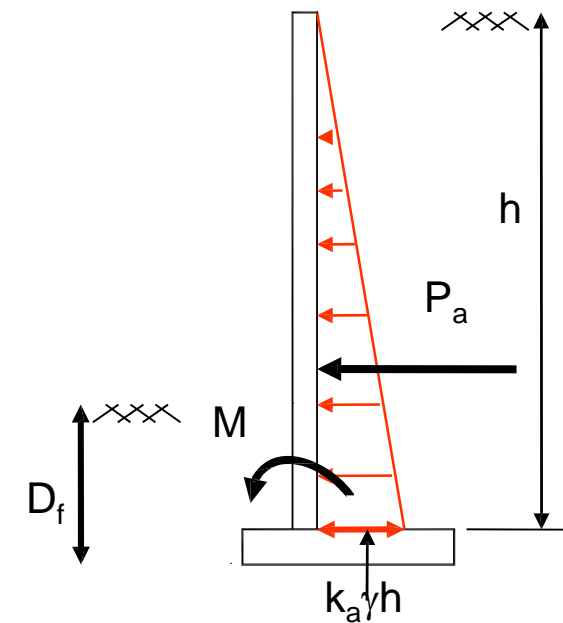

Or $M_u = [k_a \gamma H^3]/6$

Curtailment of bars-Stem

- Curtail 50% steel from top
- $(h_1/h_2)^2 = 50\%/100\% = 1/2$
- $(h_1/4.75)^2 = 1/2, h_1 = 3.36\text{m}$
- Actual point of cutoff
- $= 3.36 - L_d = 3.36 - 47 \phi_{\text{bar}} = 3.36 - 0.564 = 2.74\text{m}$ from top.

300 mm and 3d ok

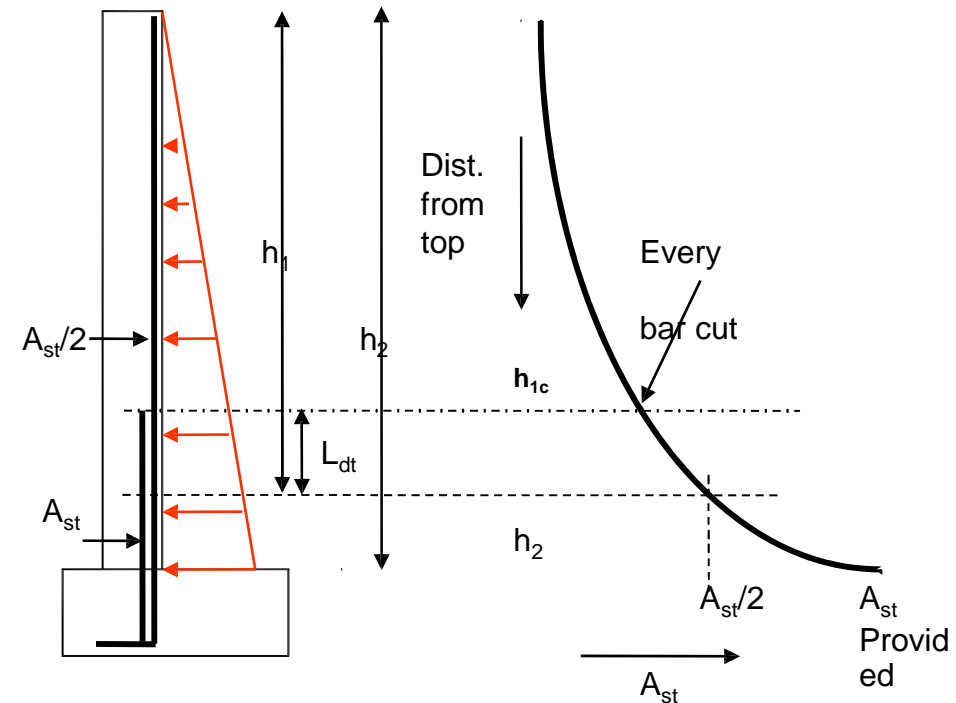

Design of stem-Contd.,

- Development length (Stem steel)
- $L_d = 47 \phi_{\text{bar}} = 47 \times 12 = 564 \text{ mm}$
- Secondary steel for stem at front
- 0.12% GA
- $= 0.12 \times 450 \times 1000 / 100 = 540 \text{ mm}^2$
- #10 @ 140 < 450 mm and 5d ok
- Distribution steel
- $= 0.12\% \text{ GA} = 0.12 \times 450 \times 1000 / 100 = 540 \text{ mm}^2$
- #10 @ 140 < 450 mm and 5d ok

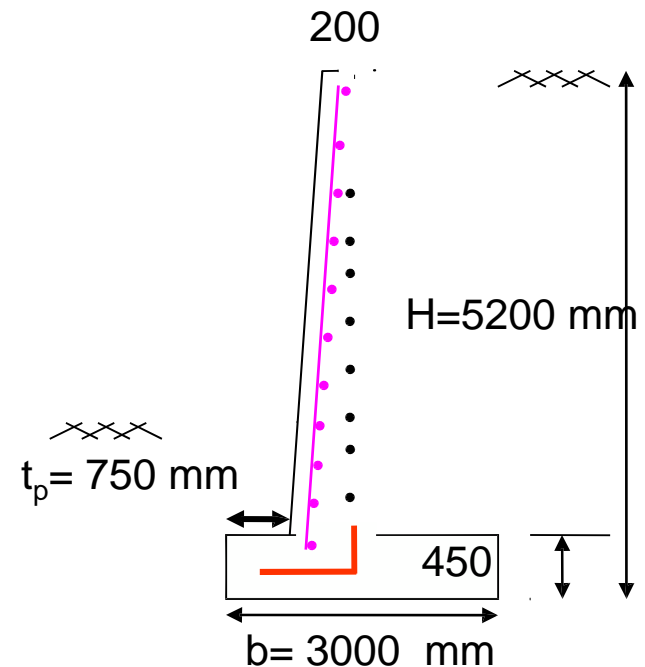

- Check for shear

- Max. SF at Junction, $xx = P_h = 67.68 \text{ kN}$
- Ultimate SF = $V_u = 1.5 \times 67.68 = 101.52 \text{ kN}$
- Nominal shear stress = $\zeta_v = V_u / bd$
- = $101.52 \times 1000 / 1000 \times 400 = 0.25 \text{ MPa}$
- To find ζ_c : $100A_{st} / bd = 0.32\%$,
- From IS:456-2000, $\zeta_c = 0.38 \text{ MPa}$
- $\zeta_v < \zeta_c$, Hence safe in shear.

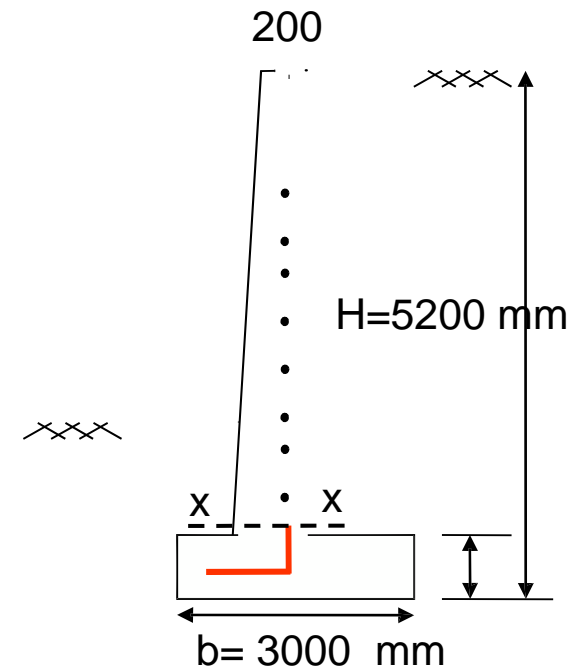

Stability analysis

Load	Magnitude, kN	Distance from A, m	BM about A kN-m
Stem W1	$0.2 \times 4.75 \times 1 \times 25 = 23.75$	1.1	26.13
Stem W2	$\frac{1}{2} \times 0.25 \times 4.75 \times 1 \times 25 = 14.84$	$0.75 + \frac{2}{3} \times 0.25 = 0.316$	13.60
B. slab W3	$3.0 \times 0.45 \times 1 \times 25 = 33.75$	1.5	50.63
Back fill, W4	$1.8 \times 4.75 \times 1 \times 18 = 153.9$	2.1	323.20
Total	$\Sigma W = 226.24$		$\Sigma M_R = 413.55$
Earth Pre. = P_H	$P_H = 0.333 \times 18 \times 5.2^2 / 2$	$H/3 = 5.2/3$	$M_O = 140.05$

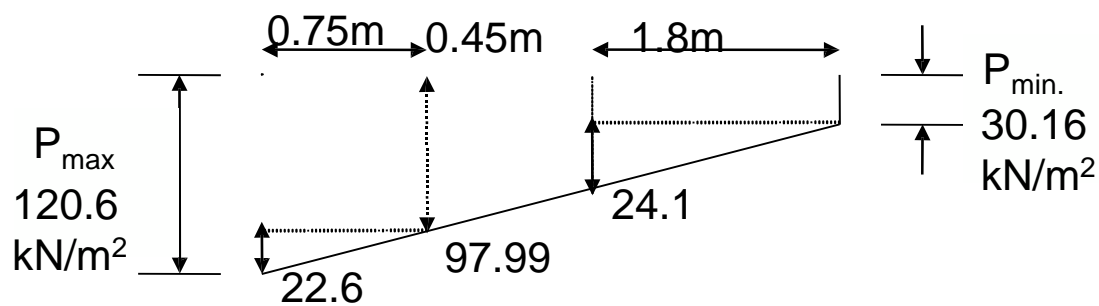
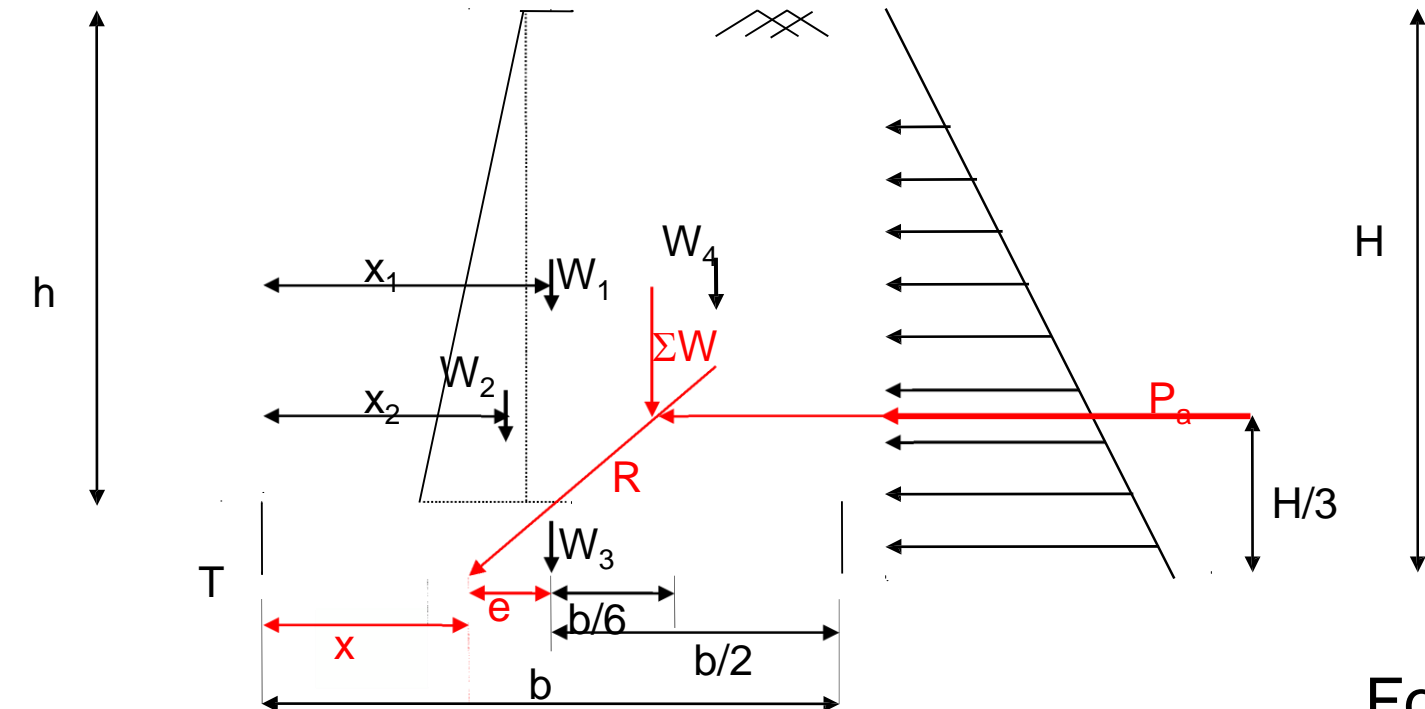

Forces acting on the wall and the pressure below the wall

Pressure below the Retaining Wall

Stability checks

- Check for overturning
- $FOS = \Sigma M_R / M_O = 2.94 > 1.55$ safe

- Check for Sliding
- $FOS = \mu \Sigma W / P_H = 2.94 > 1.55$ safe

- Check for subsidence
- $X = \Sigma M / \Sigma W = 1.20 \text{ m} > b/3$ and $e = b/2 - x = 3/2 - 1.2 = 0.3 \text{ m} < b/6$

- Pressure below the base slab
- $P_{Max} = 120.66 \text{ kN/m}^2 < \text{SBC}$, safe
- $P_{Min} = 30.16 \text{ kN/m}^2 > \text{zero}$, No tension or separation, safe



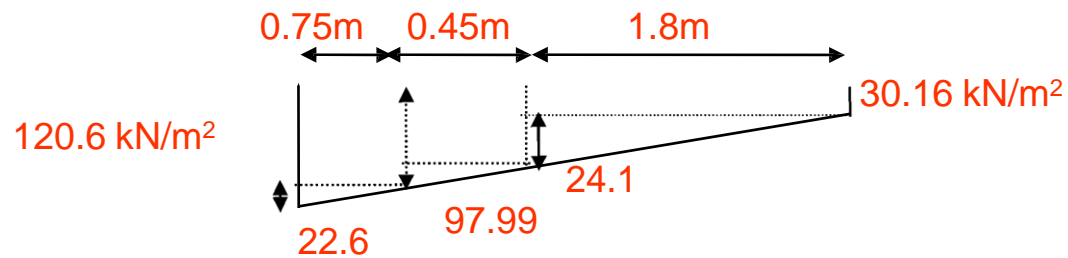

Pressure below the Retaining Wall

Load	Magnitude, kN	Distance from C, m	BM, M_C , kN-m
Backfill	153.9	0.9	138.51
Heel slab	$0.45 \times 1.8 \times 25$ = 27.25	0.9	18.23
Pressure dist. rectangle	30.16×1.8 = 54.29	0.9	-48.86
Pressure dist. Triangle	$\frac{1}{2} \times 24.1$ $\times 1.8 = 21.69$	$\frac{1}{3} \times 1.8$	-13.01
Total Load		Total	$\Sigma M_C = 94.86$

Design
of
heel
slab



Design of heel slab- Contd.,

- $M_u = 1.5 \times 94.86 = 142.3 \text{ kNm}$
- $M_u / bd^2 = 0.89 < 2.76$, URS
- $P_t = 0.264\% < 0.96\%$
- $A_{st} = 0.264 \times 1000 \times 400 / 100$
- $= 1056 \text{ mm}^2$

- #16@ 190 < 300 mm and 3d ok
- $A_{st \text{ provided}} = 1058 \text{ mm} [0.27\%]$

OR $M_u = 0.87 f_y A_{st} [d - (f_y A_{st} / f_{ck} b)]$

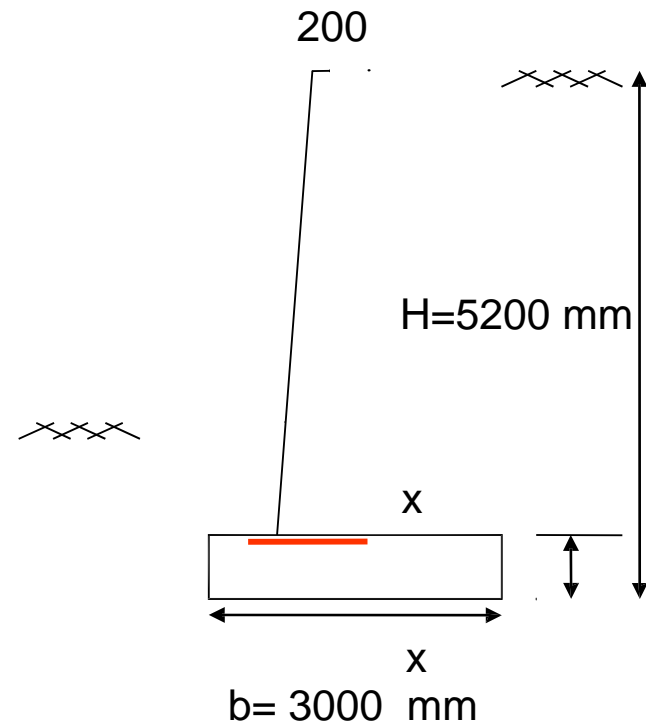

Design of heel slab- Contd.,

- Development length:
- $L_d = 47 \phi_{\text{bar}}$
- $= 47 \times 16 = 752\text{mm}$

- Distribution steel
- Same, #10 @ 140
- $< 450\text{ mm}$ and $5d$ ok

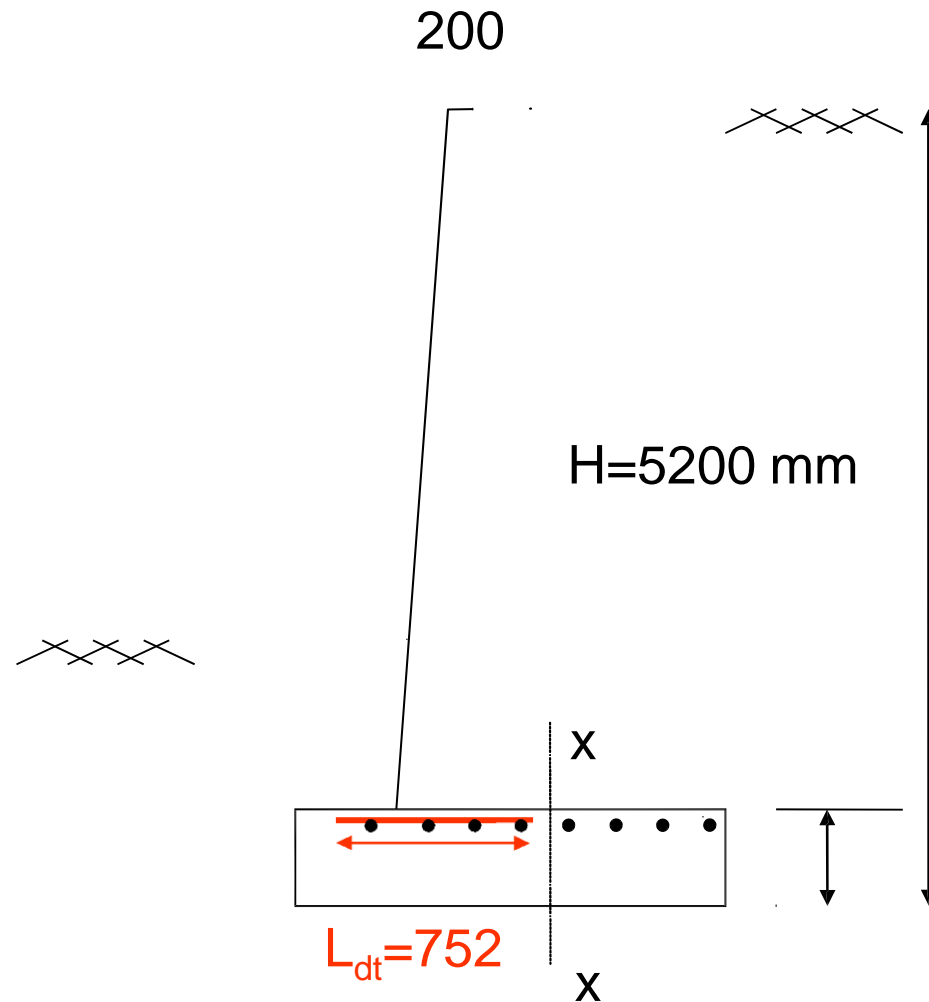

Design of heel slab-Contd.,

- Check for shear at junction (Tension)
- Maximum shear $=V=105.17$ kN,
- $V_{U,max} = 157.76$ kN,
- Nominal shear stress $=\zeta_v = V_u/bd$
- $= 101.52 \times 1000 / 1000 \times 400 = 0.39$ MPa
- To find ζ_c : $100A_{st}/bd = 0.27\%$,
- From IS:456-2000, $\zeta_c = 0.37$ MPa
- ζ_v slightly greater than ζ_c ,
- Hence slightly unsafe in shear.

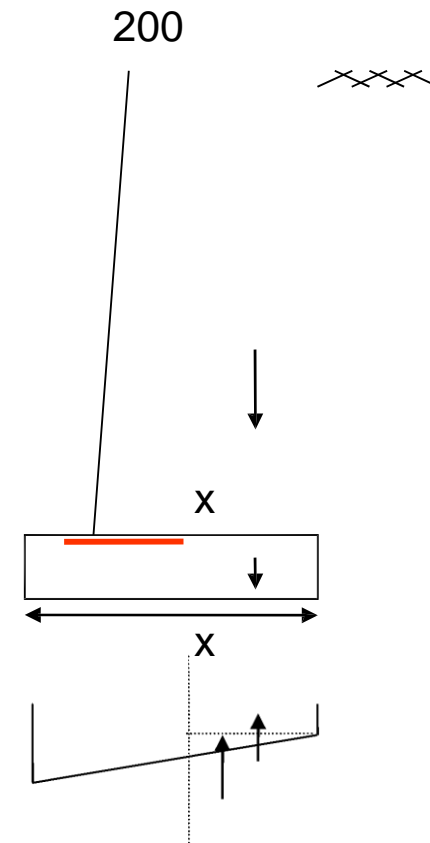

Design of toe slab

Load	Magnitude, kN	Distance from C, m	Bending moment, M_C, kN-m
Toe slab	$0.75 \times 0.45 \times 25 =$	$0.75/2$	-3.164
Pressure distribution, rectangle	97.99×0.75	$0.75/2$	27.60
Pressure distribution, triangle	$\frac{1}{2} \times 22.6 \times 1.0.75$	$\frac{2}{3} \times 1 = 0.75$	4.24
Total Load at junction		Total BM at junction	$\Sigma M = 28.67$

Design of toe slab

- $M_u = 1.5 \times 28.67 = 43 \text{ kN-m}$
- $M_u / bd^2 = 0.27 < 2.76$, URS
- $P_t = 0.085\%$ Very small, provide $0.12\% GA$
- $A_{st} = 540 \text{ mm}^2$
- #10 @ 140 < 300 mm and $3d$ ok
- Development length:
- $L_d = 47 \phi_{\text{bar}} = 47 \times 10 = 470 \text{ mm}$

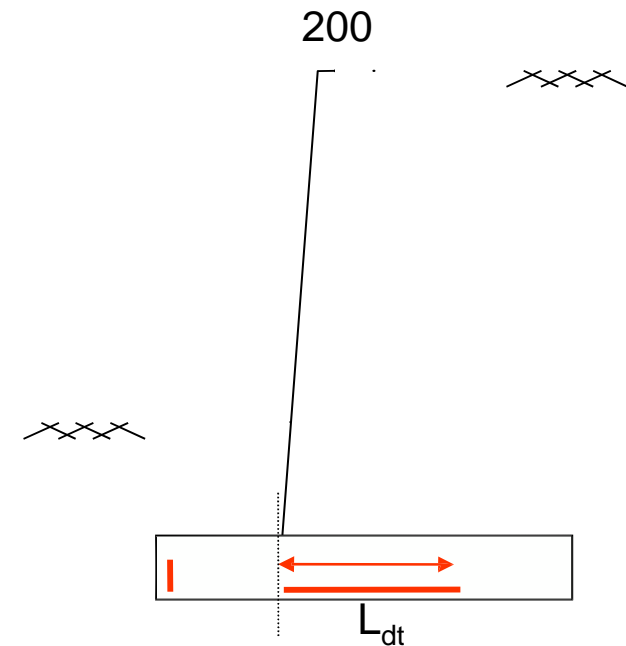

Design of toe slab-Contd.,

- Check for shear: at d from junction (at xx as wall is in compression)
- Net shear force at the section
- $V = (120.6 + 110.04) / 2 \times 0.35 - 0.45 \times 0.35 \times 25 = 75.45 \text{ kN}$
- $V_{U, \max} = 75.45 \times 1.5 = 113.18 \text{ kN}$
- $\zeta_v = 113.17 \times 1000 / (1000 \times 400) = 0.28 \text{ MPa}$
- $p_t \leq 0.25\%$, From IS:456-2000, $\zeta_c = 0.37 \text{ MPa}$
- $\zeta_v < \zeta_c$, Hence safe in shear.

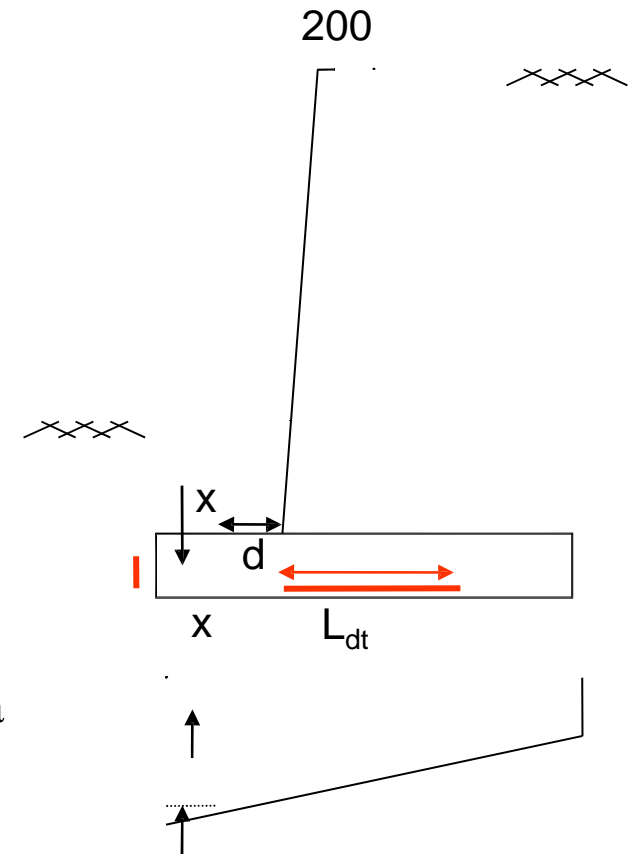

Other details

- **Construction joint**
- **A key 200 mm wide x 50 mm deep**
- **with nominal steel**
- **#10 @ 250, 600 mm length in two rows**
- **Drainage**
- **100 mm dia. pipes as weep holes at 3m c/c at bottom**
- **Also provide 200 mm gravel blanket at the back of the stem for back drain.**



Drawing and detailing

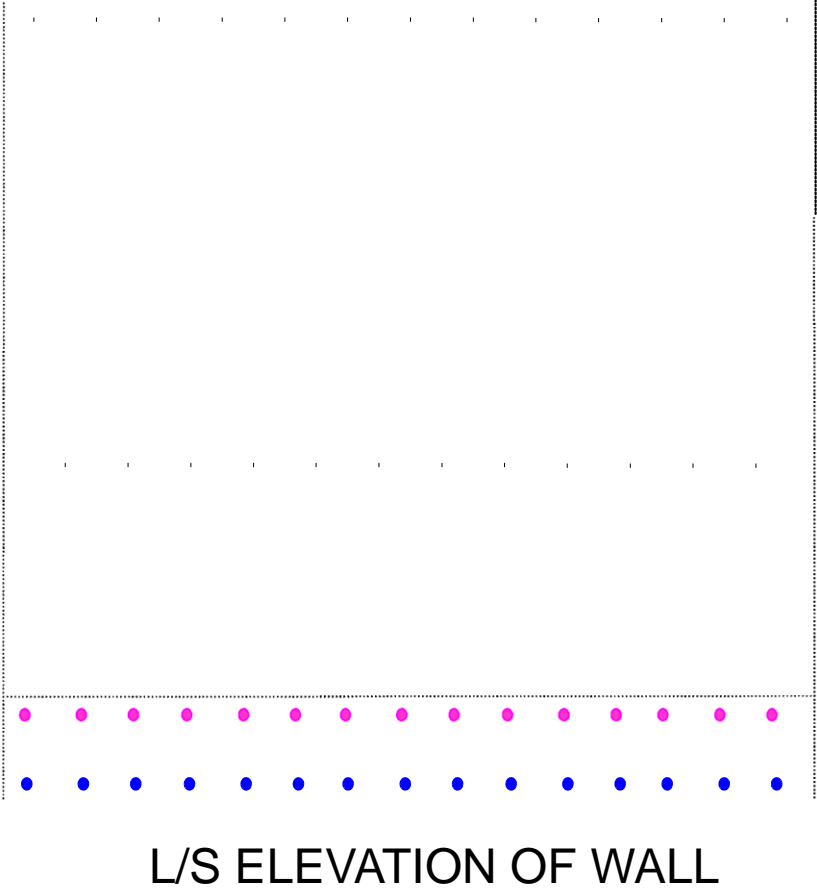
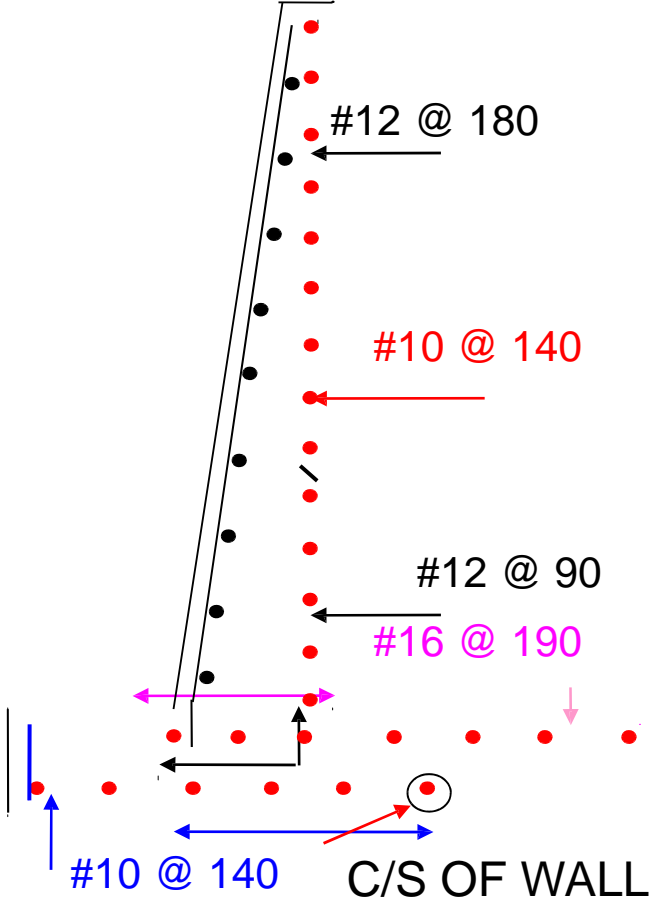

Drawing and detailing

BASE SLAB DETAILS

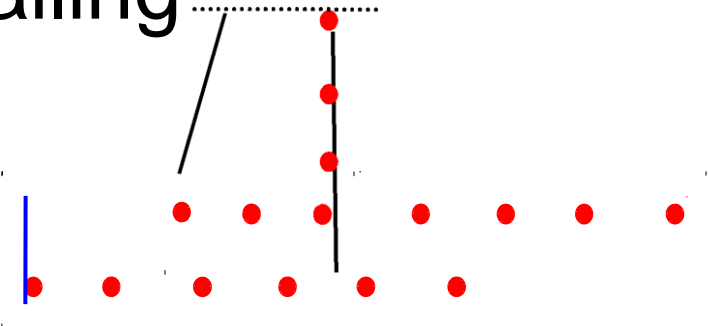

PLAN OF BASE SLAB

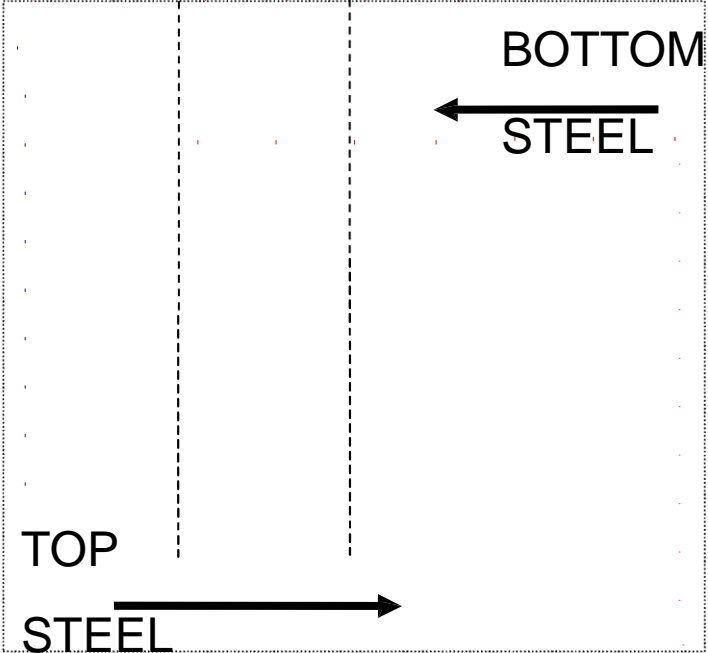

Important Points for drawing

Note

1. Adopt a suitable scale such as 1:20
2. Show all the details and do neat drawing
3. Show the development length for all bars at the junction
4. Name the different parts such as stem, toe, heel, backfill, weep holes, blanket, etc.,
5. Show the dimensions of all parts
6. Detail the steel in all the drawings
7. Lines with double headed arrows represents the development lengths in the cross section

Design and Detailing of Counterfort Retaining wall

- When H exceeds about 6m,
- Stem and heel thickness is more
- More bending and more steel
- Cantilever-T type-Uneconomical
- Counterforts-Trapezoidal section
- 1.5m -3m c/c

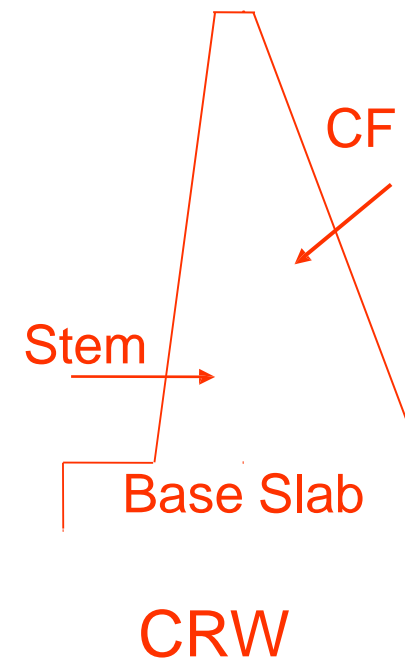

Parts of CRW

- Same as that of Cantilever Retaining wall Plus Counterfort

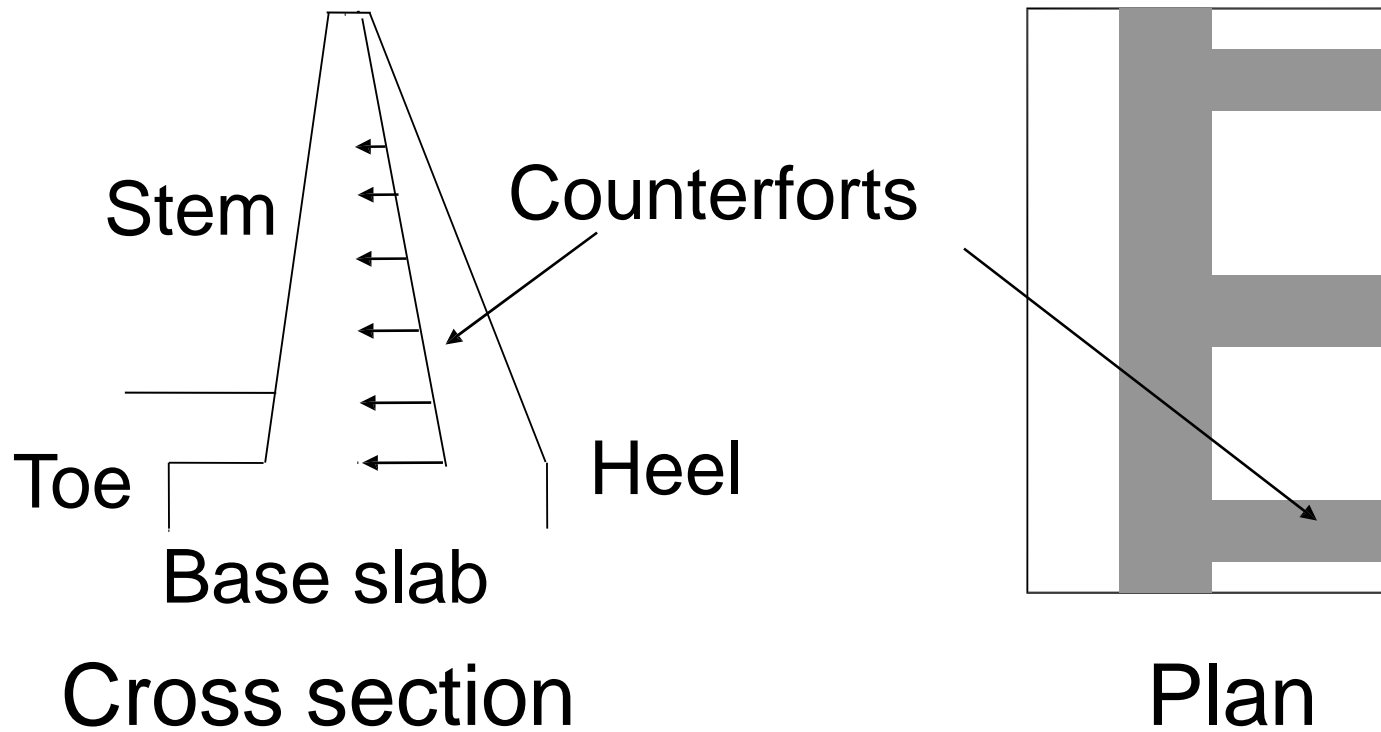

Design of Stem

- The stem acts as a continuous slab
- Soil pressure acts as the load on the slab.
- Earth pressure varies linearly over the height
- The slab deflects away from the earth face between the counterforts
- The bending moment in the stem is maximum at the base and reduces towards top.
- But the thickness of the wall is kept constant and only the area of steel is reduced.

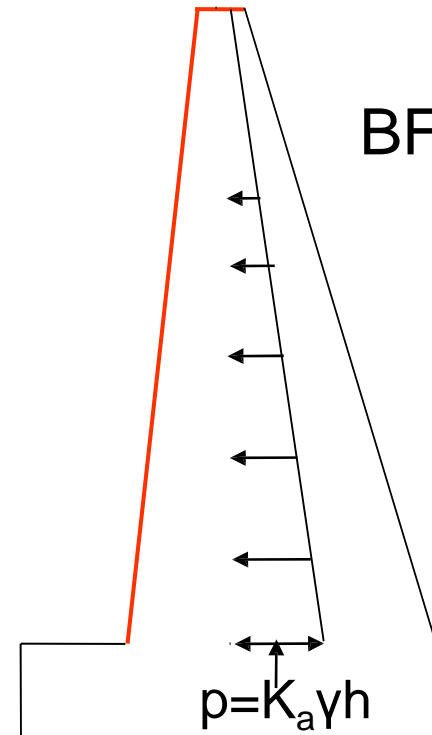

Maximum Bending moments for stem

- Maximum +ve B.M = $pl^2/16$
- (occurring mid-way between counterforts)
- and
- Maximum -ve B.M = $pl^2/12$
- (occurring at inner face of counterforts)

- Where 'l' is the clear distance between the counterforts
- and 'p' is the intensity of soil pressure

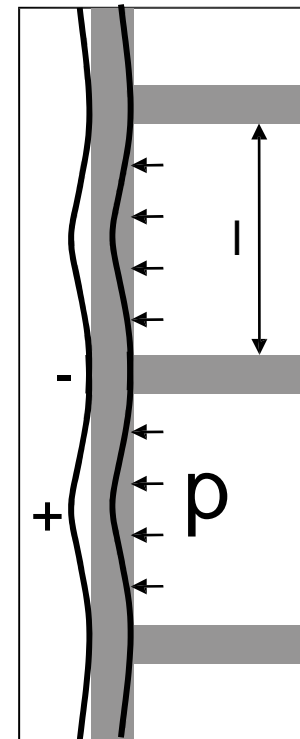

Design of Toe Slab

- The base width= $b = 0.6 H$ to $0.7 H$
- The projection= $1/3$ to $1/4$ of base width.
- The toe slab is subjected to an upward soil reaction and is designed as a cantilever slab fixed at the front face of the stem.
- Reinforcement is provided on earth face along the length of the toe slab.
- In case the toe slab projection is large i.e. $> b/3$, front counterforts are provided above the toe slab and the slab is designed as a continuous horizontal slab spanning between the front counterforts.

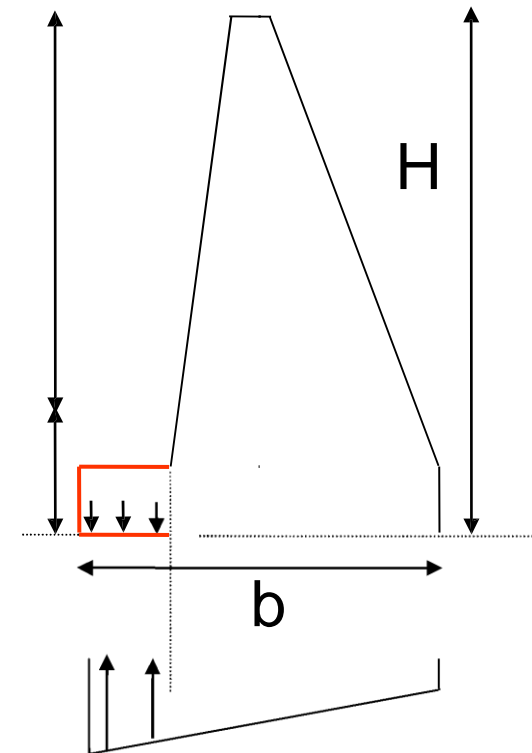

Design of Heel Slab

- The heel slab is designed as a continuous slab spanning over the counterforts and is subjected to downward forces due to weight of soil plus self weight of slab and an upward force due to soil reaction.
- Maximum +ve B.M = $pl^2/16$
(mid-way between counterforts)
- And
- Maximum -ve B.M = $pl^2/12$
(occurring at counterforts)

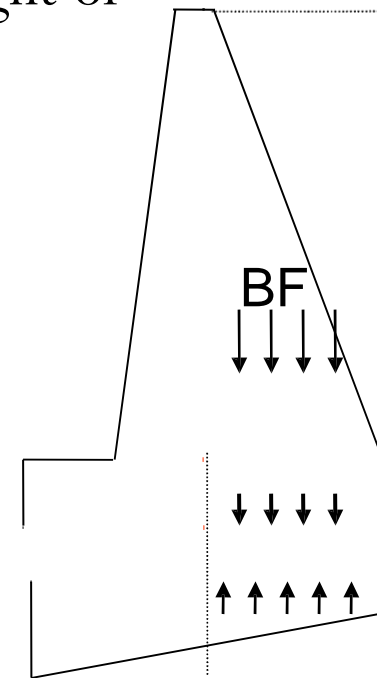

Design of Counterforts

- The counterforts are subjected to outward reaction from the stem.
- This produces tension along the outer sloping face of the counterforts.
- The inner face supporting the stem is in compression. Thus counterforts are designed as a T-beam of varying depth.
- The main steel provided along the sloping face shall be anchored properly at both ends.
- The depth of the counterfort is measured perpendicular to the sloping side.

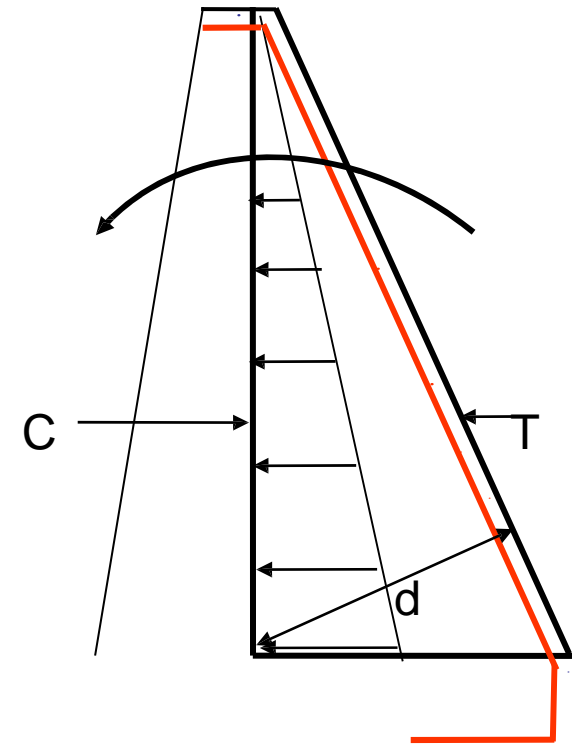

Behaviour of Counterfort RW

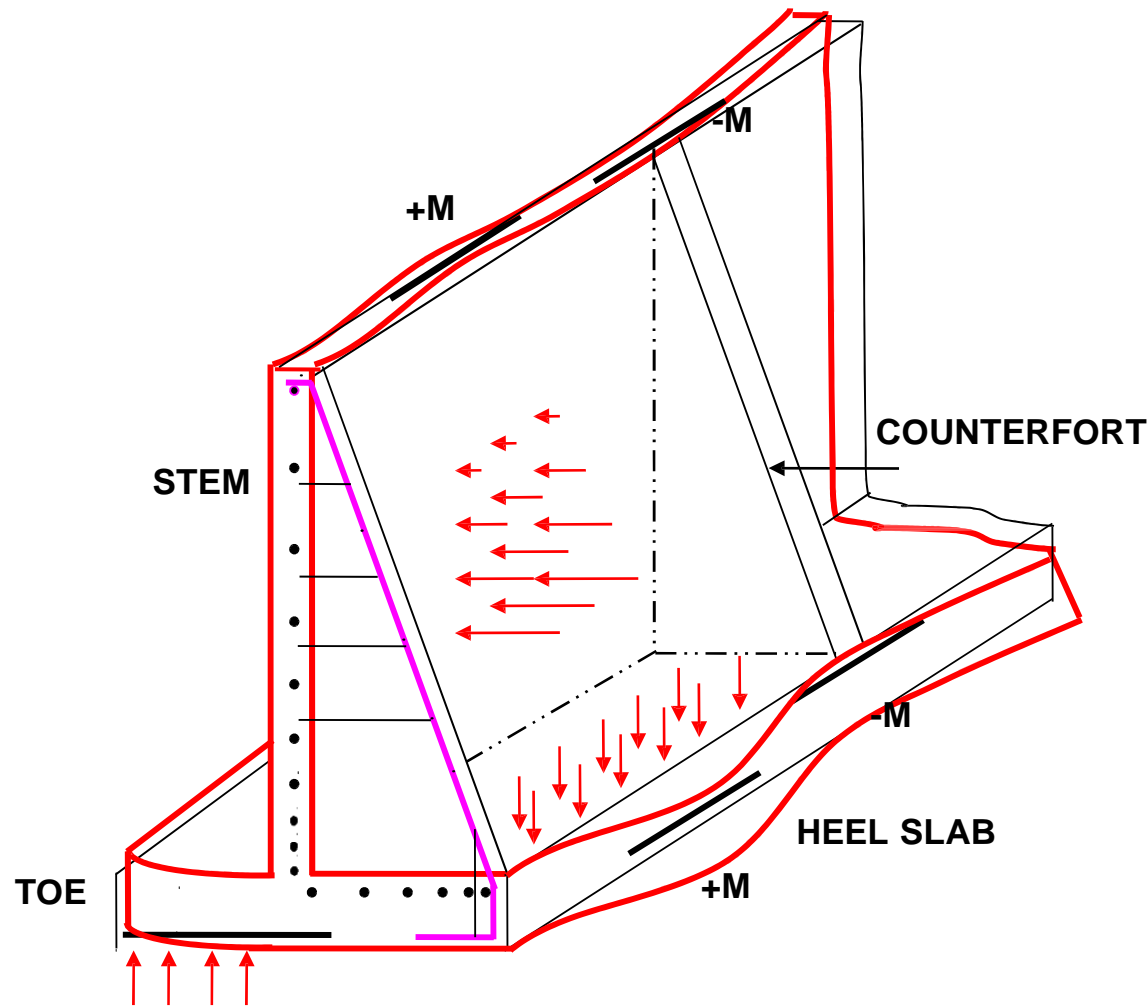

Important points

- Loads on Wall
- Deflected shape
- Nature of BMs
- Position of steel
- Counterfort details