

# What is a frame structure and how is it designed

**This is prepared by: Diyary N. Faqe Mahmood**

**This research is for the consultant degree in Kurdistan Engineers Union**

Table of content:

1. Introduction
2. What is a frame structure
3. Important parts in a frame structure
4. Advantages of frame structure
5. Types of frame structures
6. Primary components of a structural framework: columns and beams
7. Conclusion

## 1. Introduction

The purpose of this research is to further understand the type of frame structures in buildings. This will explain three different types of frame buildings concrete, steel and wood, also it will show the benefits and drawbacks of each type of the structure. This research will be very useful for engineers to decide which type of frame system can be used in order to optimize the design and be economical for the design and implementation.

## 2. What is a frame structure

A frame in construction, by definition composed of beams and columns, typically represents a fundamental element in the design of buildings and plays a crucial role in the stability and durability of a structure.

In this article, we will look at the most important aspects related to frame structures, identifying the **elements** that characterize them, the different types in relation to the different **materials** used, and the various categories of **static behavior**.

A framed structure consists of several interconnected elements, each playing a crucial role in ensuring the overall stability and functionality of the system. The frame, defined as the structural element composed of two vertical columns and a rigidly connected horizontal beam, is repeated both horizontally and vertically. This arrangement allows for static continuity and efficient use of space with limited planimetric envelopes.

The columns – vertical inter-floor elements – can be aligned or positioned at a distance from each other based on the optimal span for the floor slabs, following a regular mesh of square, rectangular, or triangular shape. The beams, the horizontal plane elements or inclined structural members transfer loads onto columns

Frame structures mainly work under bending and shear, compression, and bending compression. Columns and beams are the key elements of this structure. The column, a vertical load-bearing element, transmits loads from the superstructure to the foundation, undergoing vertical and horizontal loads, normal stress, bending moment, or bending compression.

The beam, similar to the column but with predominantly larger dimensions, is geometrically defined as a solid generated by a flat figure moving in space,

remaining orthogonal to the trajectories described by its axis. Beams can be primary or secondary, with different sections such as rectangular or I, T, L, C, H profiles, etc., in order to reduce weight and optimize material usage based on the stresses.

Beams can also have lightweight sections, such as box girders or lattice profiles. Box beams, suitable for large spans, consist of hollow closed sections with internal stiffening elements. Lattice beams, composed of vertical and diagonal rods, are ideal for axial forces and can be hinged at the nodes, providing a system of rods subjected to compression or tension, depending on their position in the lattice mesh.

### **3. Important parts of a frame structure in Construction**

The important parts of a frame structure in building construction are:

- Columns
- Beams
- Slabs
- Foundation
- Structural Walls
- Elevator Shaft

- **Columns**

A-frame building columns are an essential structural component. These vertical members carry the load from the beam and the upper columns to the feet.

The loads that are carried can be either axial or eccentric. The design of columns is far more important than that of slabs and beams because if one beam fails, it will be a local failure on one floor. But if one column fails, it could lead to the collapse and disintegration of the entire structure.

- **Beams**

The horizontal load-bearing members in the frame structure are called beams. They can carry slab loads and direct loads of masonry walls. These beams can

be supported on other beams or by columns that form an integral part of the frame. These are the flexural members.

- **Slabs**

A slab is a horizontal flat covering the building and providing shelter for its inhabitants. They are the plate element. They carry the load primarily via flexure. They are usually capable of carrying vertical loads. They can also carry large earthquake and wind forces under horizontal loads.

- **Foundation**

The foundation's sole purpose is to transfer the load from the beams and columns to the ground.

- **Shear Walls**

These structural elements are crucial for high-rise buildings. Because they look like columns, shear walls are very large columns- they are easily measured as 400mm thick by 3m long - making them appear like walls rather than columns. They are responsible for handling horizontal loads such as wind and earthquake loads. Shear walls can also carry vertical loads. It is important to know that shear walls only support horizontal loads in one direction: the axis at the wall's long dimension.

- **Elevator Shaft**

The elevator shaft is a concrete box that allows the elevator to move up or down. These shafts are very good structural elements, are designed to resist horizontal loads and carry vertical loads.

#### **4. Advantages of Framed Structure**

There are so many advantages of a frame structure below we will list all of them point by point:

- 01.** Speedy construction is possible due to its simple geometry. It can be constructed more rapidly than ordinary walled structures. It consists of only columns and beams (or partially the floor slab) as the main structural elements. It is possible to carry out several building construction activities, e.g., construction of frame work of the upper floors and finishing of the lower floors simultaneously. Hence speed in construction in a framed structure can be easily achieved.
- 02.** The strength and stability of the structures is more.
- 03.** Multi storied structures can also be constructed.
- 04.** A framed structure is better resistant to vibration. Framed structures can resist vibrations effectively and hence are ideal for buildings in seismic zones and for factory building.
- 05.** Framed structures are very rigid and stable. Framed structures are able to resist tremendous vertical (dead load) as well as lateral loads (wind), earthquake without substantial deformation/deflection.

**LOAD BEARING  
STRUCTURE**

**VS**

**FRAMED  
STRUCTURE**



## Difference Between Load Bearing Structure & Framed Structure in Structural System

- 06.** Dead load is reduced due to absence of thick load bearing walls etc.
- 07.** Every floor slab being finished becomes cover to protect the lower floors from rain and sun.
- 08.** Framed structure provides more floor areas without obstacles between columns. A non-load bearing wall between the adjacent columns and a beam over it are supported on a beam. This means that the maximum height of a wall is equal to that of story height. Thus, this form of construction requires thin panels which in turn increase the floor area. However, the external walls should be sufficiently thick to withstand weather conditions.
- 09.** Flexible utilization of space. No necessity to construct walls on walls. Any wall can be taken anywhere. Hence, flexibility in use.
- 10.** Adaptable to almost any shape.
- 11.** Framed structures can be easily altered within limits of frame. It is possible to change the position of the panel wall to meet the requirements at any time. Thus, greater freedom in planning can be easily achieved.
- 12.** Offsite preparation is possible in framed structure, especially for prefabricated construction using precast concrete or structural steel elements.
- 13.** Acceptable distribution of natural light – window openings can be provided easily on external walls.
- 14.** Easy to analyze and design structures including computer aided designs, due to simple geometry, i.e. easy methods of analysis.
- 15.** This form of construction divides building components into two distinct categories, i.e., load bearing and non-load bearing. Non-load bearing members can be constructed with low-cost materials.
- 16.** These structures are most suitable and economical on filled and soft grounds when compared to ordinary walled structures.

## 5. Types of frame structures

There are mainly two types of framed structures:

- *Rigid Frame Structures*
- *Braced Frame Structures*
  
- *Rigid Frame Structures*

Moment frame systems are also known as rigid frame systems. They consist of linear elements like beams or columns. Rigidity refers to the ability to resist deformation. It is found in reinforced concrete and steel buildings. Rigid frames lack pinned joints and are usually statically indeterminate.

A rigid frame can resist vertical and horizontal loads from the bending of columns and beams. The rigidity of a rigid frame is mainly due to the rigid connections and beams that bend rigidly. Joints must be designed to withstand significant deformation and have sufficient strength.

Structural analysis methods like the portal method (approximate), Castigliano's theorem and force methods, Castigliano's method, Castigliano's theorem and the force method, slope-displacement and stiffness methods, and the matrix analysis can be used to solve internal forces, moments, and support reactions.

Rigid frame structures can further be classified into two types:

a. Fixed end rigid frame structure

As the name suggests, this rigid frame has fixed ends as supports.

b. Pinned end rigid frame structure

As the name suggests, this rigid frame has pinned ends as supports.

- *Braced Frame Structures*

Braced frames consist of columns and beams that are “pin” connected to bracing to resist the lateral load. This frame is easy to understand and construct. Both horizontal and vertical bracing provide resistance to lateral forces.

There are many types of bracing that can be used, including knee-bracing and diagonal bracing. This frame system is more resistant to earthquakes and wind forces. This frame system is more efficient than rigid frames.

Braced frame structures can further be classified into two types:

- a. Gabled Frame Structures

Gabled frames have a structural peak at the top to ease the flow of rainwater and snow. Therefore, these frame structures are used in regions where the chances of rain and snow are high.

- b. Portal Frame Structures

As the name suggests, portal frames resemble a doorway. These frame structures are commonly used to construct industrial and commercial buildings.

Also, the frame structure can be divided into different types based on both materials and static behavior. Let's look at these differences together.

➤ **Materials**

The materials generally used for frame structures are reinforced concrete, steel, and wood.



## 1. Reinforced concrete frames

Reinforced concrete frame structures for buildings, subject to horizontal actions, can ensure stability through the implementation of structural nodes in the bays. These nodes act as energy dissipators, inserting additional reinforcement to prevent the expulsion of concrete during seismic events. Alternatively, reinforced concrete walls, for “partitional,” function or stiffening cores, such as vertical compartments, can be used.

Columns and beams in reinforced concrete frame structures can take on different forms, such as square, U, T, L, or I. Beams can vary in height, thickness, and can be extradosed. The structures can be cast in place with steel rods positioned in formwork, ensuring good continuity of stress transmission through anchoring of the metal bars in the casts.

A faster solution is the use of block-formwork in which concrete is poured. In these solutions, the columns can be made with blocks that house the reinforcement, and the beams can be made from hollow blocks. For fully or semi-prefabricated structures, different configurations can be adopted, ensuring good flexibility of use and limited production and assembly costs.

Concrete frame structures are a very common - or perhaps the most common type of modern building internationally. As the name suggests, this type of building consists of a frame or skeleton of concrete. Horizontal members of this frame are called beams, and vertical members are called columns. Humans walk on flat planes of concrete called slabs (see figure below for an illustration of each major part of a frame structure). Of these, the column is the most important, as it is the primary load carrying element of the building. If you damage a beam or slab in a building, this will affect only one floor, but damage to columns could bring down the entire building.



When we say concrete in the building trade, we actually mean reinforced concrete. Its full name is reinforced cement concrete, or RCC. RCC is concrete that contains steel bars, called reinforcement bars, or rebars. This combination works very well, as concrete is very strong in compression, easy to produce at site, and inexpensive, and steel is very very strong in tension. To make reinforced concrete, one first makes a mould, called formwork, that will contain the liquid concrete and give it the form and shape we need. Then one looks at the structural engineer's drawings and places them in the steel reinforcement bars, and ties them in place using wire. The tied steel is called a reinforcement cage, because it is shaped like one.

Once the steel is in place, one can start to prepare the concrete, by mixing cement, sand, stone chips in a range of sizes, and water in a cement mixer, and pouring in the liquid concrete into the formwork till exactly the right level is reached. The concrete will become hard in a matter of hours, but takes a month to reach its full strength.

Therefore, it is usually propped up until that period. During this time the concrete must be cured, or supplied with water on its surface, which it needs for the chemical reactions within to proceed properly.

Working out the exact 'recipe', or proportions of each ingredient is a science in itself. It is called concrete mix design. A good mix designer will start with the properties that are desired in the mix, then take many factors into account, and work out a detailed mix design. A site engineer will often order a different type of mix for a different purpose. For example, if he is casting a thin concrete wall in a hard-to-reach area, he will ask for a mix that is more flowable than stiff. This will allow the liquid concrete to flow by gravity into every corner of the framework. For most construction applications, however, a standard mix is used.

Common examples of standard mixes are M20, M30, M40 concrete, where the number refers to the strength of the concrete in (Mpa) or newtons per square millimeter. Therefore, M30 concrete will have a compressive strength of 30n/mm<sup>2</sup>. A standard mix may also specify the maximum aggregate size. Aggregates are the stone chips used in concrete. If an engineer specifies M30/20 concrete, he wants M30 concrete with a maximum aggregate size of 20mm. He does not want concrete with a strength of between 20-30 n/mm<sup>2</sup>, which is a common misinterpretation in some parts of the world.

So the structure is actually a connected frame of members, each of which are firmly connected to each other. In engineering parlance, these connections are called moment connections, which means that the two members are firmly connected to each other. There are other types of connections, including hinged connections, which are used in steel structures, but concrete frame structures have moment connections in 99.9% of cases. This frame becomes very strong, and must resist the various loads that act on a building during its lifetime.

These loads include:

- **Dead Loads:** the downwards force on the building coming from the weight of the building itself, including the structural elements, walls, facades, and the like.
- **Live Loads:** the downward force on the building coming from the expected weight of the occupants and their possessions, including furniture, books, and so on. Normally these loads are specified in building codes and structural engineers must design buildings to carry these or greater loads. These loads will vary with the use of the space, for example, whether it is residential, office, industrial to name a few. It is common for codes to require live loads for residential to be a minimum of about 200 kg/m<sup>2</sup>, offices to be 250 kg/m<sup>2</sup>, and industrial to be 1000 kg/m<sup>2</sup>, which is the same as 1T/m<sup>2</sup>. These live loads are sometimes called *imposed loads*.
- **Dynamic Loads:** these occur commonly in bridges and similar infrastructure, and are the loads created by traffic, including braking and accelerating loads.
- **Wind Loads:** This is a very important design factor, especially for tall buildings (over 20 metre height), or buildings with large surface area. Buildings are designed not to resist the everyday wind conditions, but extreme conditions that may occur once every 50 years or so. These are called *design wind speeds*, and are specified in building codes. A building can commonly be required to resist a wind force of (1.50 KN), which can be a very significant force when multiplied by the surface area of the building.
- **Earthquake Loads:** in an earthquake, the ground vigorously shakes the building both horizontally and vertically, rather like a bucking horse shakes a rider in the sport of rodeo. This can cause the building to fall apart. The heavier the building, the greater the force on it. Its important to note that both wind and earthquake impose *horizontal forces* on the building, unlike the gravity forces it normally resists, which are vertical in direction.

The concrete frame rests on foundations, which transfer the forces - from the building and on the building - to the ground.



Some other important components of concrete frame structures are:

- Walls in concrete frame buildings

Concrete frame structures are strong and economical. Hence almost any walling materials can be used with them. The heavier options include masonry walls of brick, concrete block, or stone. The lighter options include drywall partitions made of light steel or wood studs covered with the sheathing boards. The former is used when strong, secure, and sound - proof enclosures are required. And the latter when quick, flexible lightweight partitions are needed.

When brick or concrete blocks are used, it is common to plaster the entire surface - brick and concrete - with cement plaster to form a hard, long-lasting finish.

- Cladding of concrete frame structures

Concrete frame building can be clad with any kind of cladding material. Common cladding materials are glass, aluminum panels, stone sheets, ceramic facades. Since these structures can be designed for heavy loading, one could even clad them in solid masonry walls of bricks.

## **2. Steel frames Structure**

Steel frame structures are used for civil and industrial buildings. In longitudinal frames, civil buildings have vertical structures, while industrial buildings have horizontal structures with longitudinal bracing. Buildings with longitudinal frames can incorporate internal or facade vertical bracing to increase flexural rigidity. Furthermore, for tall buildings in seismic areas, solutions can be designed where the vertical supports only resist vertical loads and rigid structures handle horizontal forces.

Metal frame structures involve the on-site assembly of profiles and sections through bolting or welding. These can be solid wall, cassette, or lattice structures. Beam-column connections can be made using various techniques, such as bolting, welding, or support on brackets. Structures with industrialized systems make construction more economical, allowing prefabrication and organization of transport and assembly.

Steel frame construction is steadily increasing its market share in the construction and civil engineering sector. However, is steel framing an effective construction method compared to the alternatives? In this article we will weigh out the pros and cons of structural steel frame construction as a guide for developers and design engineers exploring different construction options.

### **Understanding Steel Frame Construction**

Steel frame construction used to be primarily used for large, simple structures, such as garages, large agricultural buildings and warehouses – as well as high-rise buildings. This is how steel frame construction is still understood in popular belief, but it is now also used for a wide range of other types of development, including offices, factories, schools, public buildings and some residential dwellings.

Steel frame construction is a good option for a diversity of projects for many reasons, including:

- Durability
- Affordability
- Sustainability

Structural steel components can quickly be fabricated off-site and then transported to the construction site when needed, minimising onsite labour

requirements and reducing the impact of variables that can delay a project, such as adverse weather.

This aside, there are several distinct advantages to steel frame construction from the point of view of fabrication, as well as a couple of disadvantages. These will be noted below:

## **Advantages of Steel Frame Construction**

Steel frame constructions offer the following advantages compared to brick, concrete and wooden constructions.

### **1) Strength & Durability**

Structural steel components are lighter and stronger than weight-bearing wood or concrete products. A typical weight-bearing steel fabrication is 30% to 50% lighter than a wooden equivalent. This makes steel frame construction far stronger and more durable than traditional wood framed alternatives.

### **2) Easy Fabrication in Different Sizes**

Steel studs are available in a variety of sizes and can be fabricated in order. This means they can be customised to bear specific loads in buildings of all different types and sizes.

### **3) Fire Resistance**

Steel frame constructions are highly resistant to fire, reducing the fire risk to a building and retarding the spread of a fire should one occur. Special flame-retardant coatings act to increase this property of structural steel.

### **4) Pest & Insect Resistant**

Structural steel components are immune to the degrading effects of burrowing insects and mammals – which can cause a problem for wooden framework unless adequately treated.

### **5) Moisture & Weather Resistance**

Structural steel can have good moisture resistant properties, depending on its carbon content. Hot zinc coating and extra powder treatments for enhanced rust

resistance will make a structural steel component even more immune to the effects of water – an important consideration for components exposed to the weather.

## **The Disadvantages of Steel Frame Construction**

Steel frame constructions do have a couple of disadvantages, the most regularly cited being:

### **1) Thermal Conductivity**

Steel is not known for its warmth, due to its high efficiency in conducting heat. The insulation value of walls can be reduced by as much as half when heat is transferred away through steel studs, which is not good news for energy retention in a building. Where steel frame construction is used, insulation measures need to be put in place to counteract the thermal conductivity of steel.

### **2) Reduced Flexibility on Site**

One of the benefits of using wooden structural components is the ability to adjust them on site. A component can be cut down to size, nails hammered in to strengthen the join and so on. This obviously can't happen with steel. The measurements of steel need to be precisely calculated in advance, because a steel fabrication is delivered to site in its final form, ready to be slotted into the building. This is of course one of the big advantages of steel, but if the fabrication has resulted in an inaccurate component for whatever reason, the project may be held up while the framework is sent back to the workshop for adjustment. You can avoid this issue by working with a fabrication company such as GLW, where we take a consultative approach to accuracy and measurements from the very beginning, to avoid any unpleasant surprises on site.

### **3) Supporting Structures**

Steel frame constructions rarely work on their own. They usually require drywall, sheathing, insulation and supplementary wooden components to bring a building together. In the opinion of some construction businesses, this longer construction time is an argument against steel frame constructions, although usually the time savings outweigh any adjustments that need to be made on site.



### **3. Wooden frames Structure**

Wooden frame structures can be made with solid wood or glued laminated timber. Connections can be made with bolts, nails, or adhesive joints. The spans of the beams and the size of the structural meshes vary according to the requirements, with wooden solutions offering design and assembly flexibility.

Connections between beams and columns can be made using angles, bolted or welded plates, bolts, or internal metal plates. Stiffening against horizontal actions can be achieved through cladding panels, floor panels, or metallic lattice bracing. Wooden frame structures can be particularly suitable for residential constructions.

Wood frame construction is one of the most widely used methods to build residential, commercial and industrial buildings. Wood frames are not only very economical to build but are also resistant to extreme climatic variations, and offer residents a high degree of comfort. Added to that, wood frames are sustainable and absorb carbon and offset greenhouse gasses.

Wood frames can be used to construct different styles of buildings and there cannot be any restriction on architectural possibilities when wood is the medium. In order for a wood building to perform its expected functions, it is necessary to construct it judiciously and this can be achieved by using sound construction and erection practices. For instance, wood frames are light in weight and hence it does not require cranes and other heavy machinery for the erection process therefore contributing to the economic aspect of construction.

#### **Foundation for Wood Frames**

Based on the type of soil and wood frame loads, a suitable foundation is specified for construction. Footings should be deep enough to avoid frost action in winter. The ground needs to be sufficiently compacted if the structure is constructed in an area where root trees have been removed or filled materials are placed. If the wood frame is constructed over poor soil, treated wood pile with wood or concrete sills can be used.

By and large, two types of foundations are widely used for wood structures: namely concrete foundation and pressure preservative treated wood foundation which are shown in Fig. 1 and Fig. 2, respectively. Apart from these, free standing

piers, piers with curtain walls, and piers supporting grading beams can also be utilized.

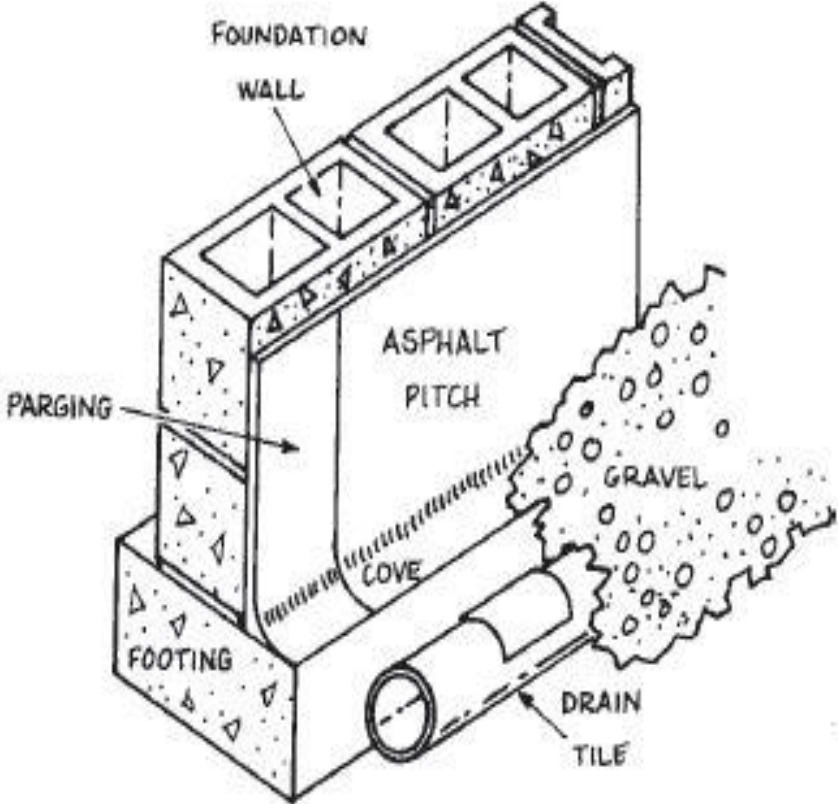
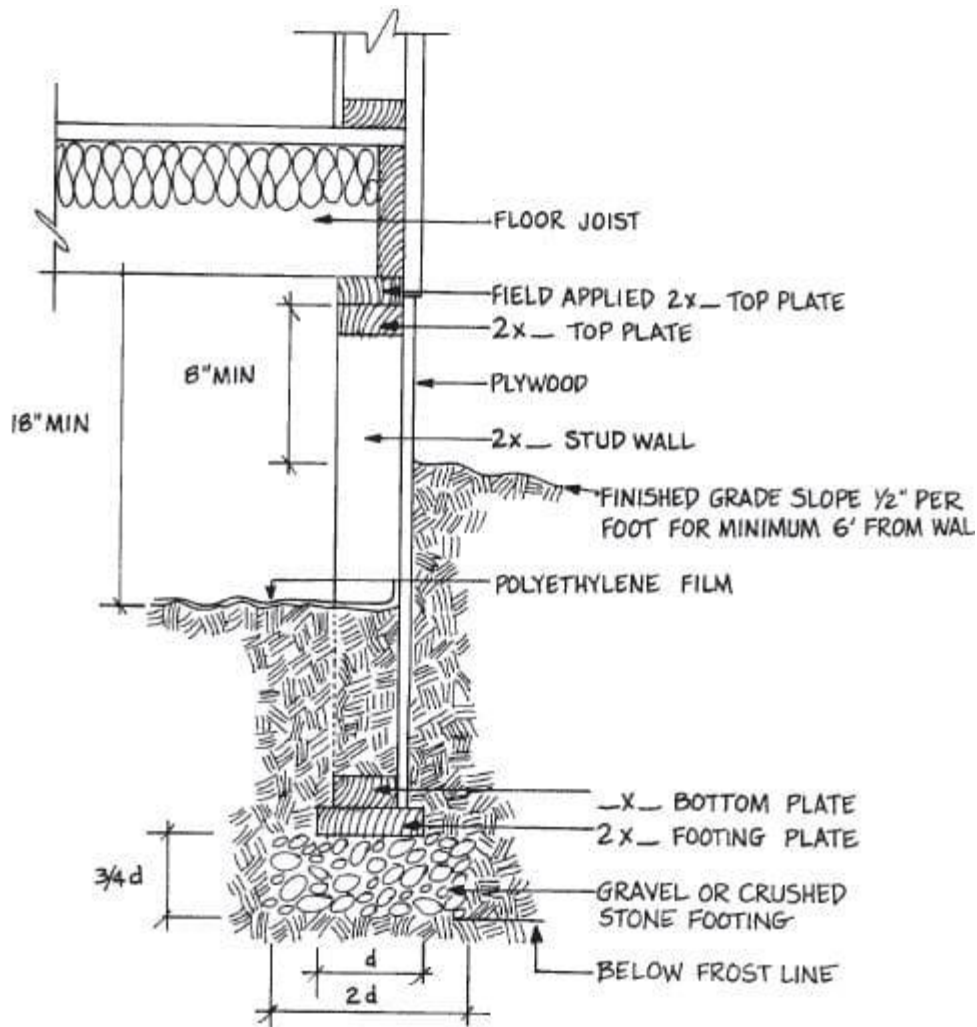

Fig. 1: Concrete Foundation



**Fig. 2: Wood Foundation**

### **Methods of Wood Frame Construction**

After the foundation has been laid, construction of wood frame structure begins. There are various types of techniques that can be used for the construction of wood frames. Suitable construction technique should be selected for a given wood structure:

# 1. Platform Frame Construction

It is an easy method and mostly suitable for the construction of houses. In this technique, first-floor joists are covered with sub-flooring to create a surface upon which exterior walls and interior partitions are erected. In the platform system, wall framing can be assembled on the floor and the entire unit can be tilted into its place.

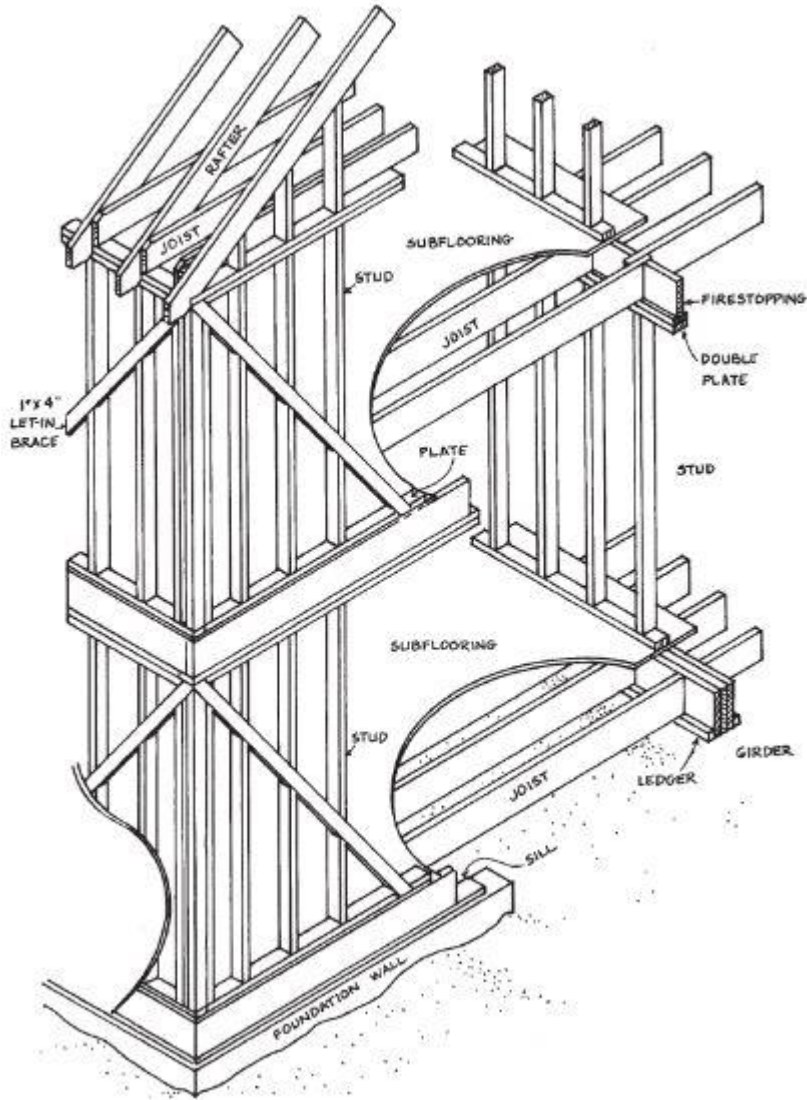

Fig. 3: Platform Frame Construction

## 2. Balloon Frame Construction

It is another method of wood frame construction which although is a bit less popular compared to platform frame construction, but is utilized when the conditions ask for it. In this method, exterior wall studs and first-floor joists are supported by anchored sill. The exterior wall studs are continuous to the second floor. The second-floor joists are supported by ribbon strip which are inserted into the inside edges of exterior wall studs.

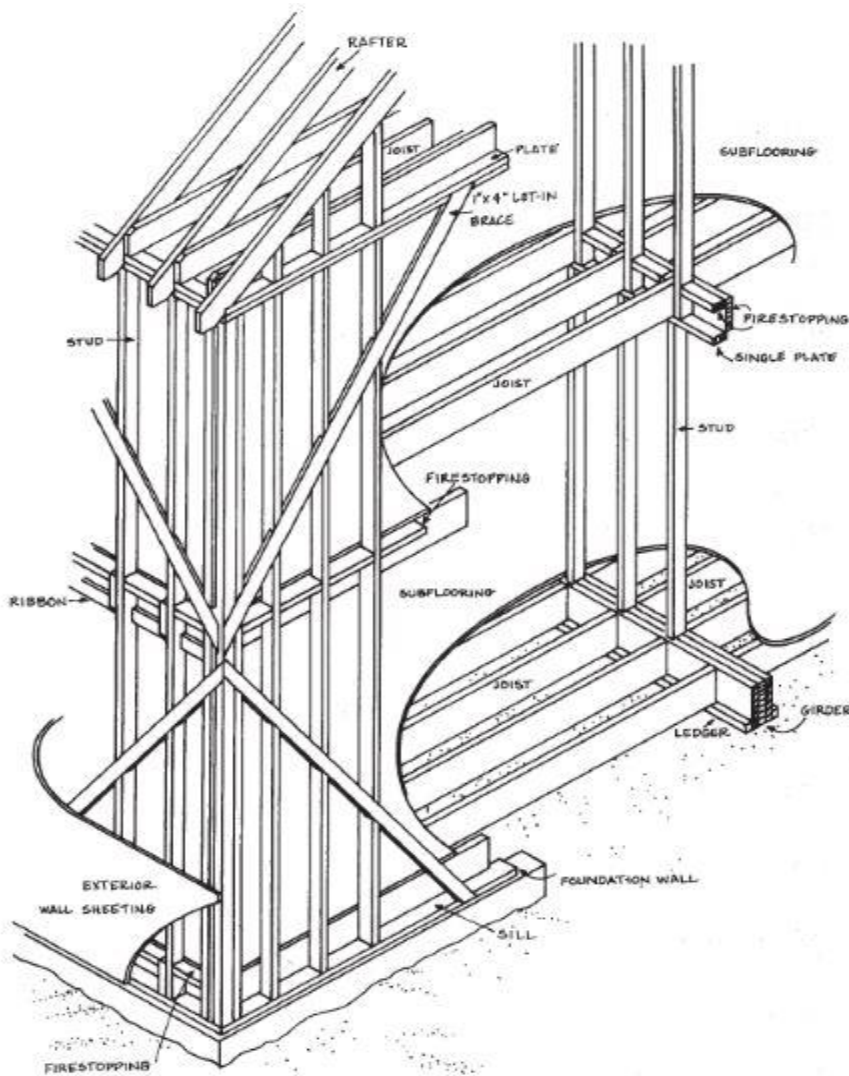

Fig. 4: Balloon Frame Construction

### 3. Plank and Beam Frame Construction

In this framing method, beams, whose ends are supported by posts, are spaced at a maximum of 2.4m and planks are used to cover floors and roofs. The posts provide wall framing and planks act as subflooring and roof sheathing. Wall sheathing is attached to supplementary framing between posts. Roof and floor loads imposed on beams, then get transferred to the posts and are finally received by foundations.

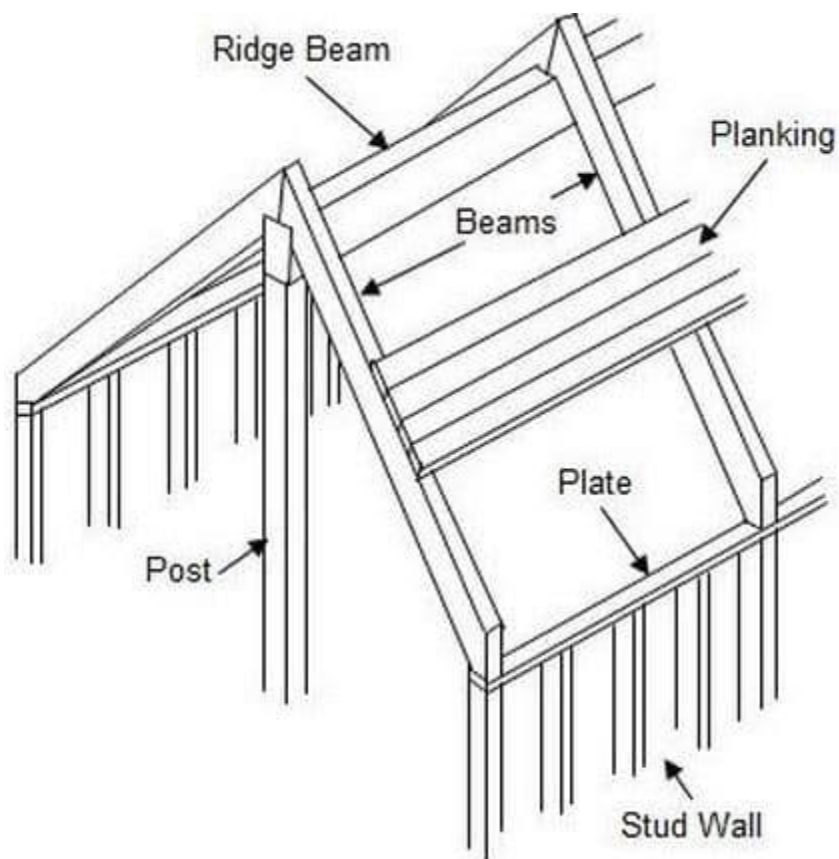

Fig. 5: Plank and Beam Construction



#### **4. Truss-Framed Construction**

In this frame construction method, roof truss, floor truss and metal anchors are used to build strong wood frames. Outstanding advantages of trussed frames are substantial rigidity and wider spacing of roof and floor supporting members.



**Fig. 6: Truss-framed Construction**

#### **Types of Fastenings for Wood Frame**

There are various fastening means which can be selected based on the size of wood elements and exerted loads used to attach different elements of wood frames together. Most common fastening techniques are discussed below:

##### **1. Nails or Combination of Nails, Anchor and Additives**

Nails or combination of nails, metal framing anchor, and construction additives are used to fasten framing lumber and sheathing panels.

## **2. Ring or Shank Nails**

Ring or shank nails are used when high loads are to be supported

## **3. Nailed Joints**

Nailed joints are used when loads act at right angles to nails, but it should be avoided if loads act parallel to the nail.

## **Wood Protection Measures**

Provision of proper means to protect wood is an indicator of good construction practice. Wood frame elements, specifically all the foundation members, shall be protected against decay and termites.

Basic protection measures include the removal of tree roots in areas around the structure prior to backfilling, carefully tamp loose backfill to decrease future settlement, and provide a certain degree of slopes at foundation and over the building to force water away from the structure.

Finally, all wood structural elements shall be treated based on the exposure to weather and closeness to ground.



## ➤ **Static behavior**

Regarding static behavior, we can have the following categories.

### **Isostatic frames**

Isostatic frames are statically determined structures, which means that it is possible to completely resolve all reactions and internal forces using equilibrium equations. These frames are characterized by a sufficient number of constraints to ensure the stability and determinacy of the system. Examples include rectangular and triangular frames, where the constraints at the junctions ensure a clear solvability of internal forces.

### **Hyperstatic frames**

Hyperstatic frames are statically indeterminate structures, which means that the number of constraints and reactive forces is not sufficient to completely resolve all reactions and internal forces. These frames require the use of more advanced methods, such as the force method or the deformation method, to obtain a solution. Examples include frames with excess supports or restrained beams, which require a more sophisticated approach in determining internal forces.

### **Fixed node frames**

Fixed node frames are characterized by rigid junctions between beams and columns. This means that the nodes cannot rotate and that the frame can resist deformations without allowing significant displacements at the junctions. These frames are often used in situations where greater rigidity and deformation resistance are required.

### **Movable node frames**

Movable node frames are characterized by flexible junctions between beams and columns. This means that the nodes can rotate, allowing greater flexibility in structural behavior. These frames are often used in situations where greater adaptability to deformations is required or to handle variable loads.

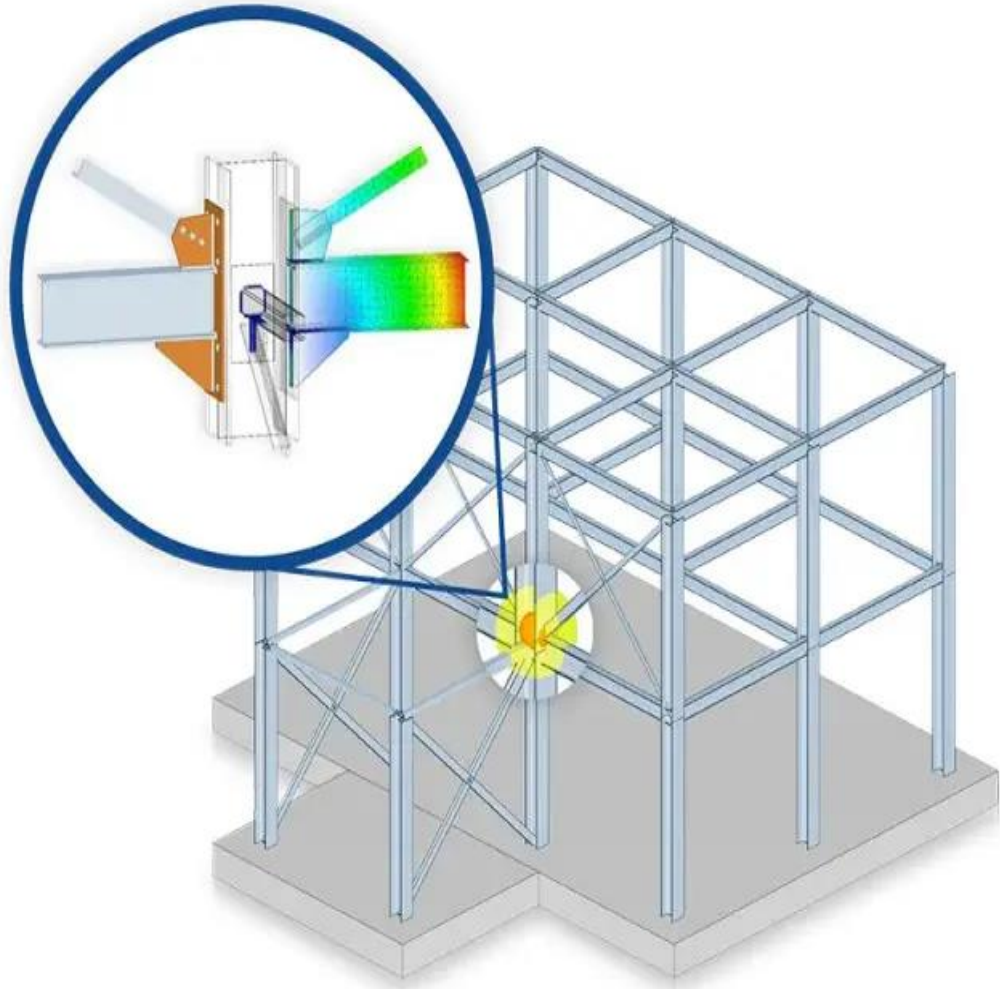

Representation of a node of a steel framed structure

## 6. Primary components of a structural framework: columns and beams

- **Reinforced concrete columns and beams**

In the design, calculation, and construction of reinforced concrete columns and beams, it is essential to comply with the regulations and current building code requirements.

The **reinforced concrete column**, to simplify the construction process, often assumes a square or rectangular shape, rarely circular. The arrangement of longitudinal iron rods is fundamental and can vary depending on the stresses in the element. The morphology and arrangement of the rods are influenced by the load and constraint conditions. The longitudinal reinforcement, placed to resist tensile stresses, is complemented by transverse reinforcement consisting of small-diameter stirrups to prevent expansions and lateral deflections.

The columns on the upper floors, with reduced loads, may have smaller dimensions but require a higher percentage of iron to resist stresses such as wind pressure. The cuts in the internal and perimeter columns are made to balance the loads in each section, ensuring a barycentric resultant.

Reinforced concrete columns can be cast in place or prefabricated in the workshop. The rods and stirrups of prefabricated columns are generally of smaller diameter compared to those of cast-in-place columns.

As for the **beams**, these exploit the mechanical characteristics of concrete to resist compressive stresses, while steel, in the form of steel bars, manages tensile actions. For spans up to 8-10 meters, full-section reinforced concrete beams can be used; for spans greater than 10 meters, a double system of main and secondary beams is recommended. For even larger spans, pre-stressed reinforced concrete beams can be used.

To ensure safety in case of fire, the steel reinforcement of columns and beams must be properly covered with at least 2 cm of concrete (cover), increased to 4 cm in aggressive environments.

The choice of the optimal dimensions of the beams depends on various factors, including the base/height ratio and the orientation of the supported, cantilevered or bracketed beam.

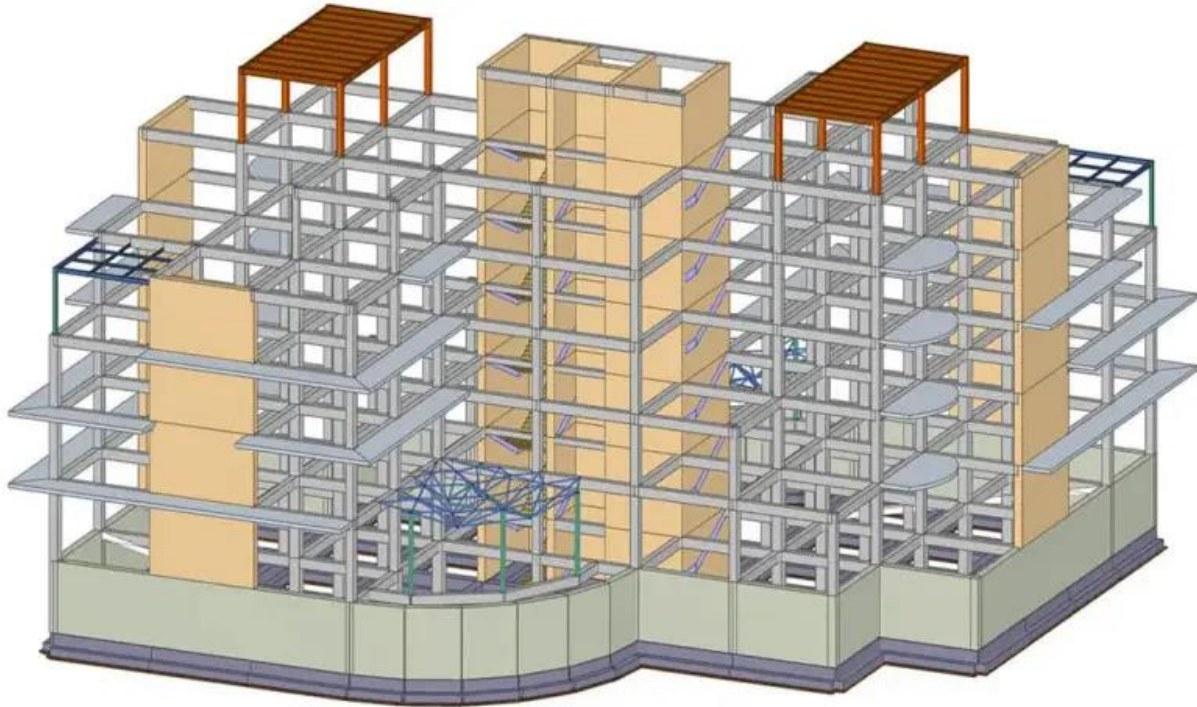

Concrete framed structure made with Edulis

- **Steel columns and beams**

**Steel columns** can take on different shapes, including circular, square or rectangular profiles, characterized by a lower vulnerability to instability effects due to slenderness. Alternatively, it is possible to create a column by combining semi-finished products which, through connections, constitute composite elements. The type of connection between the composite elements influences the structural behavior: bolting and riveting require movable elements and pre-drilling, while welding, thanks to metal fusion, avoids the need for drilling, thus obtaining monolithic elements.

The load-bearing capacity of a steel column is influenced by its slenderness, which in turn guides the choice of the cross-section. Circular tubular profiles offer the maximum inertia to lateral bending, while square sections show good

behavior under concentrated loads. However, the use of these profiles is limited due to the difficulties and costs associated with assembly with other structural elements. Open sections are subject to bending and, for critical loads, also to torsion. IPE and HEA sections are the most commonly used.

The **steel beam** can be designed as a solid wall (with single or composite section profiles), as a box or lattice. "Double T" profiles are commonly used as load-bearing beams, while other types such as "C", "L", "T", etc., are used to form composite or lattice beams. The height of the simple "double T" beam depends on the bending moment acting on the beam. In case of excessive height of a single profile, it is possible to use spaced twin elements and connected separately to the column or coupled to each other.

The connection between the various parts of a composite steel column occurs 40-50 cm above the floor level. The two column trunks can have the same section or different sections, and the connection can be made by welding or bolting.

The **solid wall beam** is mainly used to cover large spans with high loads, such as road and railway bridges.

**Lattice beams**, composed of elements arranged in a grid, are suitable for covering intermediate spans and are characterized by high strength and ductility. The choice between continuous or non-continuous beams depends on the joint conditions. The connection between the components of the lattice beam can be made with bolts or welds.

The verification of steel beams includes the verification of stresses, deformations, and local instabilities.

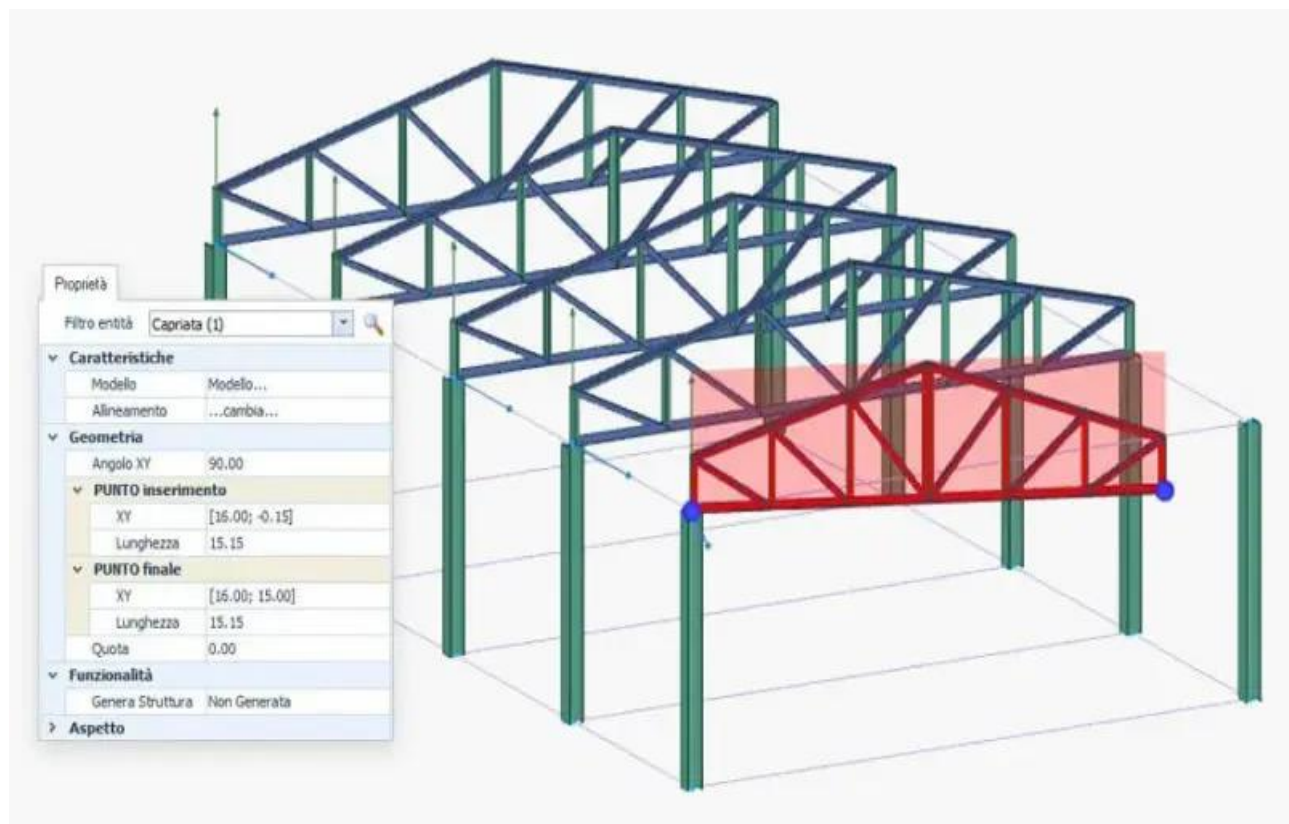

Steel framed structure made with Edulis

- **Wooden columns and beams**

**Wooden columns**, often made with T or I-shaped box sections or by coupling elements, show excellent resistance to both compression and bending. However, excessively slender and inadequately braced columns in their length can be subject to instability phenomena, with possible lateral deflection due to concentrated loads. These phenomena can be accentuated by the presence of knots, deviations of the wood fibers, low material rigidity, or eccentric loads.

Simple **wooden beams** can have conical or rectangular shapes, depending on the wood profile.

**Laminated wood columns and beams** are made up of successive layers of selected and glued wood strips (lamellae). These elements boast high mechanical strength, are resistant to hygro-thermal variations, and show low vulnerability to attacks by parasites and fire.

Through the use of glued laminated wood or new composite materials, it is possible to give beams different shapes, such as tapered, angled, longitudinally curved, or lattice beams, according to specific structural requirements.

The sizing criterion for a solid wood beam will be different from that of a laminated wood beam, as the choice of material influences the behavior, characterized by different elasticity and deformability of the various parts.



Wooden framed structure made with Edulis

Concrete frame construction refers to a method of building that uses columns and beams to transfer loads from the structure to the foundation. It acts as a



structural framework for the building and supports other members like Floors, Roofs, Walls, Claddings, and Walls.

There are many types of frame structures that can be used in building Construction. There are two main types of frame structures: braced and rigid. They can be further sub-categorized into different forms, such as pin-ended rigid and fixed end rigid structures, while the latter is broken down into gabled or portal frames.

Frame structures can be made from different materials, including reinforced concrete, steel and wood. Frame structures comprise a combination beam, column, and slab that can withstand lateral and gravitational loads. These structures are often used to overcome large moments that result from the applied loading.

## **7. Conclusion**

This research focused on the definition of frame structure and all the important parts. It is mainly composed of beams and columns that plays a crucial role in the stability and durability of a structure. There are mainly two types of framed structures: Rigid Frame Structures and Braced Frame Structures. Later, it is explained the advantages and disadvantages of a frame structure. Then, the primary components of a structural framework are explained in different types of buildings: concrete frame, steel frame, wooden frame. The benefits of this research are for engineers to understand the different types of frame structure in order to make a good decision and get useful information for design and implementation.